

DF5, DV5

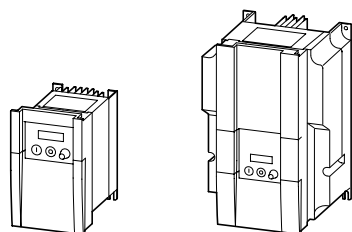

DF6, DV6

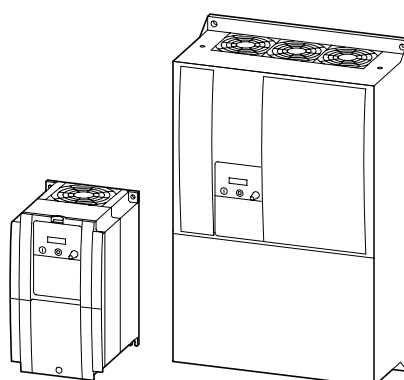

Accessories

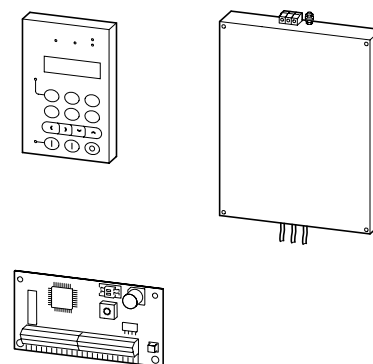

	Page
System overview	18/2
Description	
DF5 frequency inverters	18/4
DV5 vector frequency inverters	18/5
Engineering	
Assigned switching and protective elements for DF5	18/6
Assigned switching and protective elements for DV5	18/7
Wiring examples	18/8
DF5 frequency inverters	18/12
DV5 vector frequency inverters	18/13
Technical data	
DF5-322 frequency inverters	18/14
DF5-340 frequency inverters	18/18
DV5-322 vector frequency inverters	18/22
DV5-340 vector frequency inverters	18/26
Dimensions	18/78

	Page
System overview	18/30
Description	
DF6 frequency inverters	18/32
DV6 vector frequency inverters	18/33
Engineering	
Assigned switching and protective elements for DF6	18/34
Assigned switching and protective elements for DV6	18/35
Wiring examples	18/36
DF6 frequency inverters	18/38
DV6 vector frequency inverters	18/39
Technical data	
DF6 frequency inverters	18/40
DV6 vector frequency inverters	18/48
Dimensions	18/78

	Page
Description	
DE...-LZ... radio interference filters	18/56
DE5-KEY-RO3 keypad	18/62
DE5-CBL-...-ICL connection cables	18/62
DEX-KEY-10 keypad	18/63
DEX-CBL-...-ICS connection cables	18/63
DE6-IOM-ENC encoder interface module	18/64
DE5-NET-DP PROFIBUS DP interface	18/65
DE6-NET-DP PROFIBUS DP interface	18/66
DEX-CBL-2M0-PC PC connection cable	18/67
DE4-B... braking unit	18/68
DE4-BR1... braking resistors	18/68
DEX4-LN... mains chokes	18/69
DEX-LM... motor chokes	18/70
MK-K., PR... potentiometers	18/70
DE...-LZ... radio interference filters	18/57
Mains chokes	18/73
Motor chokes	18/74
Accessories	18/71
Technical data	
DE...-LZ... radio interference filters	18/58
Mains chokes	18/77
Motor chokes	18/77
Dimensions	
DE5-... radio interference filters	18/79
DE6-... radio interference filters	18/80
Mains chokes	18/81
Motor chokes	18/82
Braking units	18/82
Braking resistors	18/83
Potentiometers	18/83



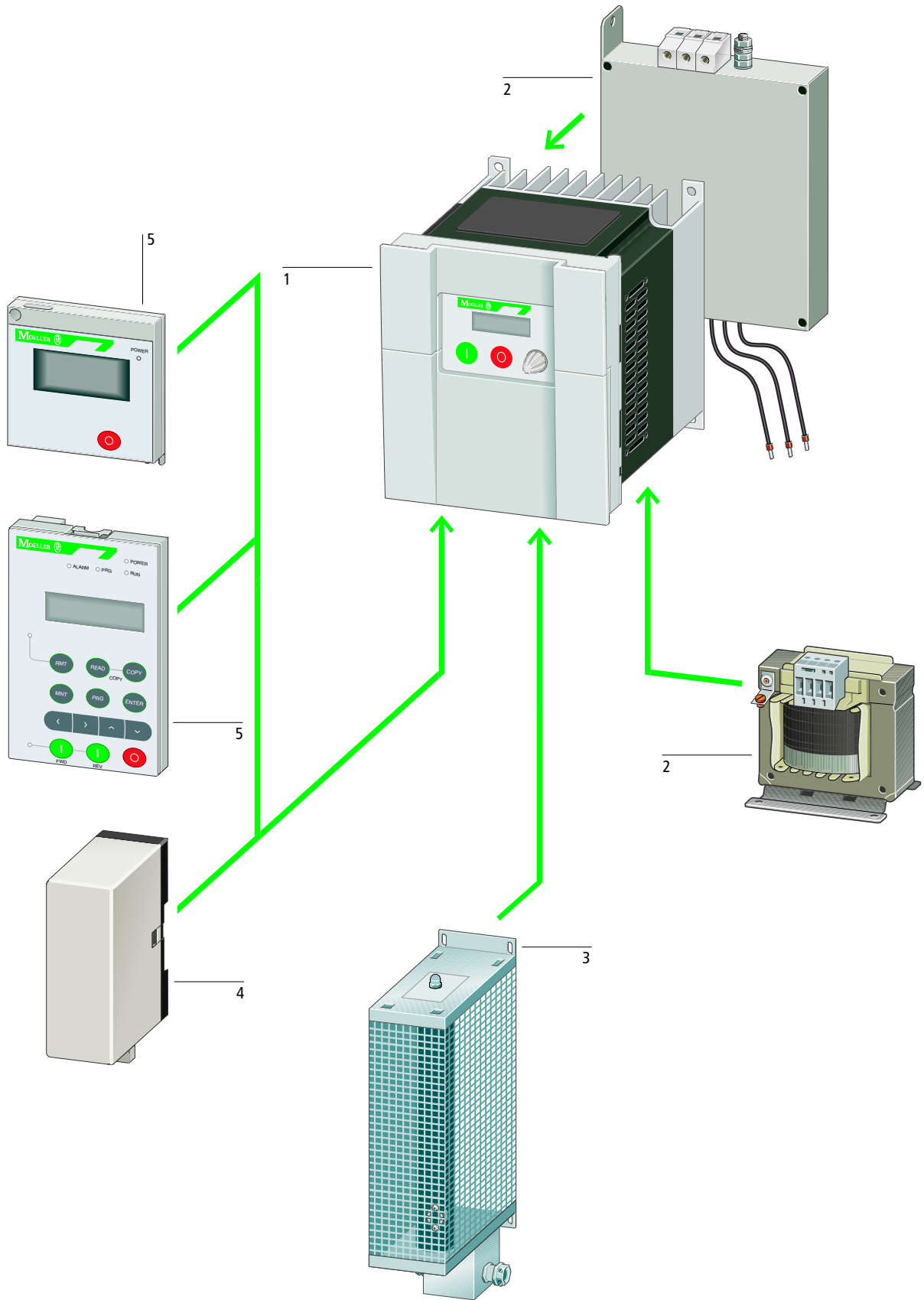

DF5 frequency inverters, DV5 vector frequency inverters

Moeller HPL0211-2004/2005

Basic units

Frequency inverters 1

DF5-322-...

Mains: 230 V single-phase/3-phase

Motor rating
from 0.18 to 2.2 kW (230 V)

→ Page 18/14

Frequency inverters 1

DF5-340-...

Mains: 400 V 3-phase

Motor rating
from 0.37 to 7.5 kW (400 V)

→ Page 18/14

Vector frequency inverters 1

DV5-322-...

Mains: 230 V single-phase/3-phase

Motor rating
from 0.18 to 2.2 kW (230 V)

→ Page 18/15

Vector frequency inverters 1

DV5-340-...

Mains: 400 V 3-phase

Motor rating
from 0.37 to 7.5 kW (400 V)

→ Page 18/15

System accessories

Keypads 5

DE5-KEY-R03

External display unit

DEX-KEY-10

External LCD keypad with memory
function

DE...-CBL-...

Connection cable for external display and
control units

→ Page 18/73

Communication modules 4

DE5-NET-DP

PROFIBUS DP interface

→ Page 18/73

Accessories

Radio interference suppression filter 2

DE5-LZ...

→ Page 18/59

Mains chokes 2

DEX-LN...

→ Page 18/71

Motor chokes 2

DEX-LM...

→ Page 18/76

Braking resistor 3

DE4-BR1-...

Enclosed (IP 20) high-capacity resistors
with temperature switch, for connecting to
the DV5's braking transistor

→ Page 18/77





Application

The DF5 frequency inverters provide infinitely variable speed control of three-phase motors. They are particularly suitable for applications where operating and economic efficiency play a central role.

The assigned performance range for four-pole three-phase asynchronous motors ranges from

- 0.18 kW to 2.2 kW at 230 V
- 0.37 kW to 7.5 kW at 400 V.

The DF5 can be used as a stand-alone drive or incorporated in automation systems. With its function-generator *U/f* (voltage/frequency) control, it can be used in a wide range of applications, from simple pump and fan drives to flexible standard drives in packaging machines and in the food and beverages industry.

Features

- Compact construction due to highly-integrated module technology
- Integrated keypad with four-character seven-segment display, six function keys and a setpoint value potentiometer
- Serial interface (RS 422) for:
 - External display and keypad
 - Data transfer via an external PROFIBUS DP module
 - Data transfer to the PC
- Five digital inputs (24 V DC)
- Two digital outputs (24 V DC)
- Two analog inputs (0 to +10 V, 4 to 20 mA)
- A relay (changeover contact: 24 V DC/230 V AC)
- Thermistor input
- Two voltage categories:
 - 230 V (180 V -0 % to 252 V +0 %), single- or three-phase mains connection
 - 400 V (342 V -0 % to 506 V +0 %), three-phase mains connection.
- Conformance to global standards CE, UL, cUL, CSA and cTick

Function

Comprehensive protective functions guarantee safe operation and protect frequency inverters and motors:

- Overcurrent, earth fault
- Overload, electronic motor protection
- Overtemperature
- Overvoltage, undervoltage

Further operating functions:

- PID controller
- Automatic voltage control (boost)
- Restart inhibit
- Min./max. frequency limitation
- Frequency hopping (frequency masking)

Documentation

Each DF5 series frequency inverter is supplied with an instruction sheet (AWA) for mounting and connection and a CD. The AWA contains a short description with illustrations and information about correct handling, installation and electrical connection of the device. The text information supplied is printed in seven languages (English, Chinese, French, German, Italian, Russian, and Spanish). The CD contains detailed descriptions and the operating manuals as well as a configuration software with help text.

Note:

To use the CD, you need a PC with the Windows operating system (98, ME, NT, 2000 or XP). For connecting a PC (RS 232) to a DF5 frequency inverter (RS 422), you will need the DEX-CBL-2M0-PC connection cable.



Moeller HPL0211-2004/2005



Application

With their sensorless vector control, the DV5 frequency inverters offer superior levels of torque for demanding applications.

The assigned performance range for four-pole three-phase asynchronous motors ranges from

- 0.18 kW to 2.2 kW at 230 V
- 0.37 kW to 7.5 kW at 400 V.

The DV5 can be used as a stand-alone drive or incorporated in automation systems. Sensorless vector control offers wide-ranging usage in the textiles, paper and printing industries, in all areas of the metalworking industry, and in hoisting and material handling systems.

Features

- Compact construction due to highly-integrated modular technology
- Integrated keypad with four-character seven-segment display, six function keys and a setpoint value potentiometer
- Serial interface (RS 422) for:
 - External display and keypad
 - Data transfer via an external PROFIBUS DP module
 - Data transfer to the PC
- Six digital inputs (24 V DC)
- Two digital outputs (24 V DC)
- Two analog inputs (0 to +10 V, 4 to 20 mA)
- A relay (changeover contact: 24 V DC/230 V AC)
- Thermistor input
- Two voltage categories:
 - 230 V (180 V -0 % to 252 V +0 %), single- or three-phase mains connection
 - 400 V (342 V -0 % to 506 V +0 %), three-phase mains connection.
- Conformance to global standards CE, UL, cUL, CSA and cTick

Function

Comprehensive protective functions guarantee safe operation and protect frequency inverters and motor:

- Overcurrent, earth fault
- Overload, electronic motor protection
- Overtemperature
- Overvoltage, undervoltage

Further operating functions:

- 200 % starting torque
- Internal braking transistor
- PID controller
- Automatic voltage control (boost)
- Restart inhibit
- Min./max. frequency limitation
- Frequency hopping (frequency masking)

Documentation

Each DV5 frequency inverter is supplied with an instruction sheet (AWA) for mounting and connection, and a CD.

The AWA contains a short description with illustrations and information about correct handling, installation and electrical connection of the device. The text information supplied is printed in seven languages (English, Chinese, French, German, Italian, Russian, and Spanish).

The CD contains a detailed manual (English, German) and configuration software with help text.

Note:

To use the CD, you need a PC with the Windows operating system (98, ME, NT, 2000 or XP). For connecting a PC (RS 232) to a DV5 frequency inverter (RS 422), you will need the DEX-CBL-2M0-PC connection cable.



	Motor Assigned motor rating P kW	Frequency inverter		Power supply				
		Rated operational current I_e A	Mains current Without mains choke or mains filter I_N A	Mains fuse ¹⁾	Mains contactor	Mains choke ²⁾	Radio interference suppression filter	Motor choke
DF5 frequency inverters								
Single-phase power supply (230 V AC)								
DF5-322-018	0.18	1.4	3.1	FAZ-B10/1N	DIL00M	DEX-LN1-006	DE5-LZ1-007-V2	DEX-LM3-005
DF5-322-037	0.37	2.6	5.8	FAZ-B10/1N	DIL00M	DEX-LN1-006	DE5-LZ1-007-V2	DEX-LM3-005
DF5-322-055	0.55	3	6.7	FAZ-B10/1N	DIL00M	DEX-LN1-009	DE5-LZ1-012-V2	DEX-LM3-005
DF5-322-075	0.75	4	9	FAZ-B16/1N	DIL00M	DEX-LN1-009	DE5-LZ1-012-V2	DEX-LM3-005
DF5-322-1K1	1.1	5	11.2	FAZ-B16/1N	DIL00M	DEX-LN1-013	DE5-LZ1-024-V2	DEX-LM3-005
DF5-322-1K5	1.5	7.1	16	FAZ-B25/1N	DIL00M	DEX-LN1-018	DE5-LZ1-024-V2	DEX-LM3-008
DF5-322-2K2	2.2	10	22.5	FAZ-B40/1N	DIL0M	DEX-LN1-024	DE5-LZ1-024-V2	DEX-LM3-011
DF5 frequency inverters								
Three-phase power supply (230 V AC)								
DF5-322-018	0.18	1.4	1.8	PKM0-10 ³⁾	DIL00M	DEX-LN3-004	DE5-LZ3-007-V4	DEX-LM3-005
DF5-322-037	0.37	2.6	3.4	PKM0-10 ³⁾	DIL00M	DEX-LN3-004	DE5-LZ3-007-V4	DEX-LM3-005
DF5-322-055	0.55	3	3.9	PKM0-10 ³⁾	DIL00M	DEX-LN3-004	DE5-LZ3-007-V4	DEX-LM3-005
DF5-322-075	0.75	4	5.2	PKM0-16 ³⁾	DIL00M	DEX-LN3-006	DE5-LZ3-007-V4	DEX-LM3-005
DF5-322-1K1	1.1	5	6.5	PKM0-20 ³⁾	DIL00M	DEX-LN3-006	DE5-LZ3-007-V4	DEX-LM3-005
DF5-322-1K5	1.5	7.1	9.3	PKM0-16 ³⁾	DIL00M	DEX-LN3-010	DE5-LZ3-011-V4	DEX-LM3-008
DF5-322-2K2	2.2	10	13	PKM0-25 ³⁾	DIL00M	DEX-LN3-016	DE5-LZ3-020-V4	DEX-LM3-011
DF5 frequency inverters								
Three-phase power supply (400 V AC)								
DF5-340-037	0.37	1.5	2	PKM0-10 ³⁾	DIL00M	DEX-LN3-004	DE5-LZ3-007-V4	DEX-LM3-005
DF5-340-075	0.75	2.5	3.3	PKM0-10 ³⁾	DIL00M	DEX-LN3-004	DE5-LZ3-007-V4	DEX-LM3-005
DF5-340-1K5	1.5	3.8	5	PKM0-10 ³⁾	DIL00M	DEX-LN3-006	DE5-LZ3-007-V4	DEX-LM3-005
DF5-340-2K2	2.2	5.5	7	PKM0-10 ³⁾	DIL00M	DEX-LN3-010	DE5-LZ3-011-V4	DEX-LM3-008
DF5-340-3K0	3	7.8	10	PKM0-16 ³⁾	DIL00M	DEX-LN3-010	DE5-LZ3-011-V4	DEX-LM3-008
DF5-340-4K0	4	8.6	11	PKM0-16 ³⁾	DIL00M	DEX-LN3-010	DE5-LZ3-011-V4	DEX-LM3-011
DF5-340-5K5	5.5	13	16.5	PKM0-25 ³⁾	DIL0M	DEX-LN3-016	DE5-LZ3-020-V4	DEX-LM3-016
DF5-340-7K5	7.5	16	20	PKM0-25 ³⁾	DIL0M	DEX-LN3-025	DE5-LZ3-020-V4	DEX-LM3-016

Notes

- ¹⁾ If single-phase frequency inverters are used without mains chokes in networks with critical stations (reactive-power compensation equipment, etc.), current peaks may occur when the mains contactor is switched on. This may cause premature tripping of the FAZ-B... To prevent this, connect an upstream mains choke or use an FAZ-C...
- ²⁾ Mains chokes reduce the harmonic currents by up to 30 % and extend the frequency inverters' lifespan.
- ³⁾ Short-circuit protection for mounting in control panel (no overload release required).

Use FAZ for mains protection → Main Catalogue 2004/2005, Industrial Switchgear, section 12
 Use PKM for mains protection → Main Catalogue 2004/2005, Industrial Switchgear, section 8
 DIL mains contactors → Main Catalogue 2004/2005, Industrial Switchgear, section 5
 DEX-LN-... mains chokes → Page 18/73



Moeller HPL0211-2004/2005

	Motor	Frequency inverter		Power supply					
		Assigned motor rating	Rated operational current	Mains current	Mains fuse ¹⁾	Mains contactor	Mains choke ²⁾	Radio interference suppression filter	Motor choke
				Without mains choke or mains filter					
<i>P</i> kW	<i>I_e</i> A	<i>I_N</i> A							
DV5 frequency inverters									
Single-phase power supply (230 V AC)									
DV5-322-018	0.18	1.4	3.5	FAZ-B10/1N	DIL00M	DEX-LN1-006	DE5-LZ1-007-V2	DEX-LM3-005	
DV5-322-037	0.37	2.6	5.8	FAZ-B10/1N	DIL00M	DEX-LN1-006	DE5-LZ1-007-V2	DEX-LM3-005	
DV5-322-055	0.55	3	6.7	FAZ-B10/1N	DIL00M	DEX-LN1-009	DE5-LZ1-007-V2	DEX-LM3-005	
DV5-322-075	0.75	4	9	FAZ-B16/1N	DIL00M	DEX-LN1-009	DE5-LZ1-012-V2	DEX-LM3-005	
DV5-322-1K1	1.1	5	11.2	FAZ-B16/1N	DIL00M	DEX-LN1-013	DE5-LZ1-012-V2	DEX-LM3-005	
DV5-322-1K5	1.5	8	17.5	FAZ-B25/1N	DIL00M	DEX-LN1-018	DE5-LZ1-024-V2	DEX-LM3-008	
DV5-322-2K2	2.2	11	24	FAZ-B40/1N	DIL0M	DEX-LN1-024	DE5-LZ1-024-V2	DEX-LM3-011	
DV5 frequency inverters									
Three-phase power supply (230 V AC)									
DV5-322-018	0.18	1.4	2	PKM0-10 ³⁾	DIL00M	DEX-LN3-004	DE5-LZ3-007-V4	DEX-LM3-005	
DV5-322-037	0.37	2.6	3.4	PKM0-10 ³⁾	DIL00M	DEX-LN3-004	DE5-LZ3-007-V4	DEX-LM3-005	
DV5-322-055	0.55	3	3.9	PKM0-10 ³⁾	DIL00M	DEX-LN3-004	DE5-LZ3-007-V4	DEX-LM3-005	
DV5-322-075	0.75	4	5.2	PKM0-16 ³⁾	DIL00M	DEX-LN3-006	DE5-LZ3-007-V4	DEX-LM3-005	
DV5-322-1K1	1.1	5	6.5	PKM0-20 ³⁾	DIL00M	DEX-LN3-006	DE5-LZ3-007-V4	DEX-LM3-005	
DV5-322-1K5	1.5	8	10	PKM0-16 ³⁾	DIL00M	DEX-LN3-010	DE5-LZ3-011-V4	DEX-LM3-008	
DV5-322-2K2	2.2	11	14	PKM0-25 ³⁾	DIL00M	DEX-LN3-016	DE5-LZ3-020-V4	DEX-LM3-011	
DV5 frequency inverters									
Three-phase power supply (400 V AC)									
DV5-340-037	0.37	1.5	2	PKM0-10 ³⁾	DIL00M	DEX-LN3-004	DE5-LZ3-007-V4	DEX-LM3-005	
DV5-340-075	0.75	2.5	3.3	PKM0-10 ³⁾	DIL00M	DEX-LN3-004	DE5-LZ3-007-V4	DEX-LM3-005	
DV5-340-1K5	1.5	3.8	5	PKM0-10 ³⁾	DIL00M	DEX-LN3-006	DE5-LZ3-007-V4	DEX-LM3-005	
DV5-340-2K2	2.2	5.5	7	PKM0-10 ³⁾	DIL00M	DEX-LN3-010	DE5-LZ3-007-V4	DEX-LM3-008	
DV5-340-3K0	3	7.8	10	PKM0-16 ³⁾	DIL00M	DEX-LN3-010	DE5-LZ3-011-V4	DEX-LM3-008	
DV5-340-4K0	4	8.6	11	PKM0-16 ³⁾	DIL00M	DEX-LN3-010	DE5-LZ3-011-V4	DEX-LM3-011	
DV5-340-5K5	5.5	13	16.5	PKM0-25 ³⁾	DIL0M	DEX-LN3-016	DE5-LZ3-020-V4	DEX-LM3-016	
DV5-340-7K5	7.5	16	20	PKM0-25 ³⁾	DIL0M	DEX-LN3-025	DE5-LZ3-020-V4	DEX-LM3-016	

Notes

- ¹⁾ If single-phase frequency inverters are used without mains chokes in networks with critical stations (reactive-power compensation equipment, etc.), current peaks may occur when the mains contactor is switched on. This may cause premature tripping of the FAZ-B... To prevent this, connect an upstream mains choke or use an FAZ-C...
- ²⁾ Mains chokes reduce the harmonic currents by up to 30 % and extend the frequency inverters' lifespan.
- ³⁾ Short-circuit protection for mounting in control panel (no overload release required).

Use FAZ for mains protection → Main Catalogue 2004/2005, Industrial Switchgear, section 12
 Use PKM for mains protection → Main Catalogue 2004/2005, Industrial Switchgear, section 8
 DIL mains contactors → Main Catalogue 2004/2005, Industrial Switchgear, section 5
 DEX-LN-... mains chokes → Page 18/73



DF5-322-... frequency inverters

Actuation

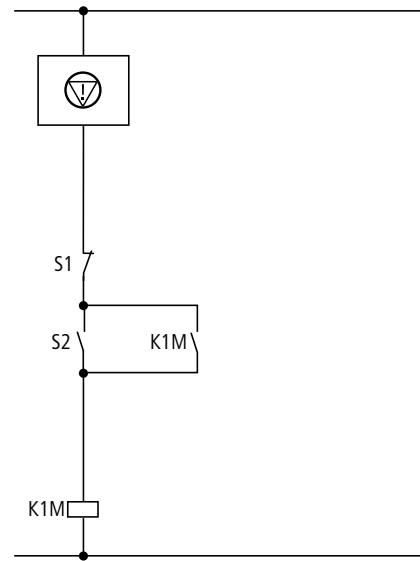

Example 1

Reference input from potentiometer R1
Enable (START/STOP) and selection of rotating direction through terminals 1 and 2 with internal control voltage

-  Emergency-Stop circuit
- S1: OFF
- S2: ON
- K1M: Mains contactor
- F1: Line protection
- PES: PE connection of cable screen
- M1: 230 V 3-phase motor

Note: For EMC-conformant mains connection, suitable radio interference suppression measures must be implemented according to product standard IEC/EN 61800-3.

Wiring

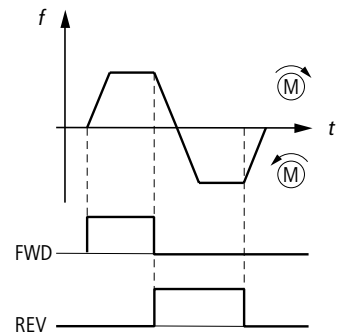
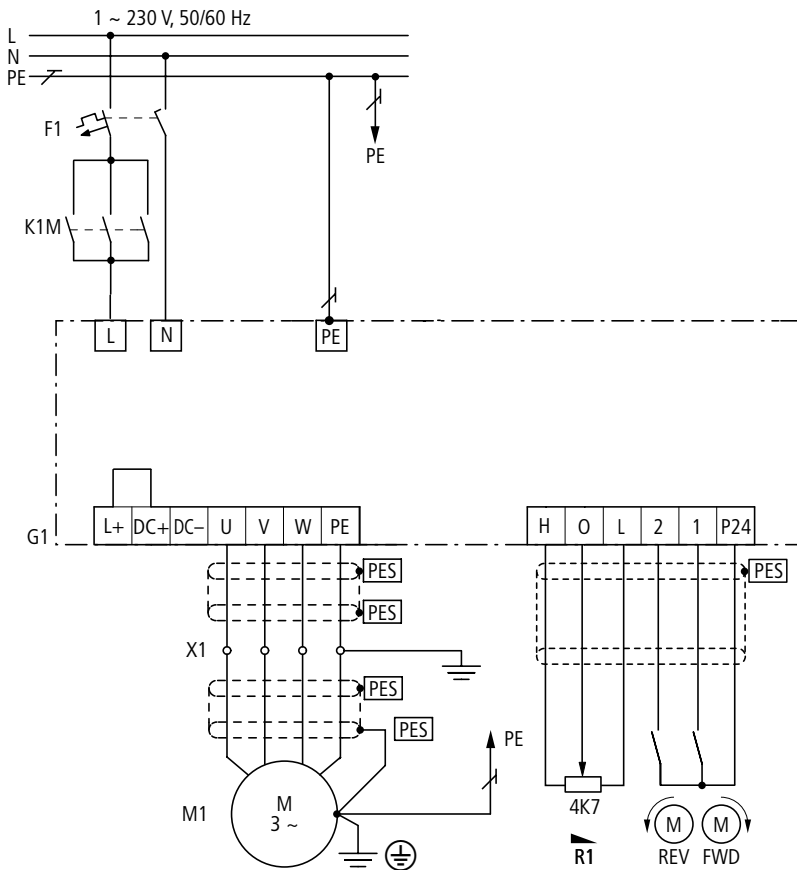

FWD: Clockwise rotating field enable
REV: Anticlockwise rotating field enable

DF5, DF6 frequency inverters
DV5, DV6 vector frequency inverters



Moeller HPL0211-2004/2005

DF5-340-... frequency inverters with EMC-conformant connection

Actuation

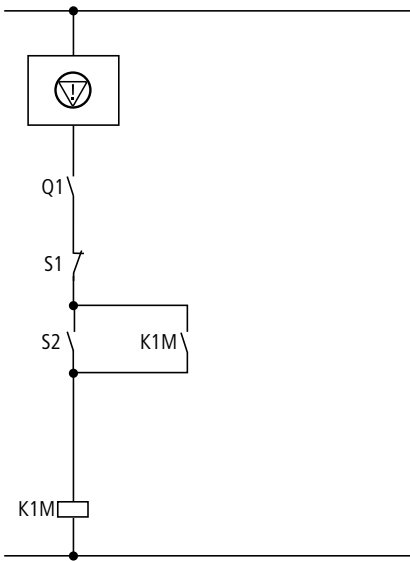

Example 2

Reference input through potentiometer R1 (f_s) and fixed frequency (f_1, f_2, f_3) through terminals 3 and 4 with internal control voltage
Enable (START/STOP) and selection of rotating direction through terminal 1

- Emergency-Stop circuit
- S1: OFF
- S2: ON
- K1M: Mains contactor
- L1: Mains choke
- Z1: Radio interference suppression filter
- Q1: Line protection
- PES: PE connection of cable screen
- M1: 400 V 3-phase motor

- FWD: Clockwise rotating field enable, reference frequency f_s
- FF1: Fixed frequency f_1
- FF2: Fixed frequency f_2
- FF1+FF2: Fixed frequency f_3

Wiring

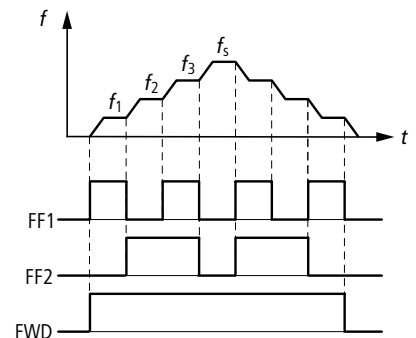
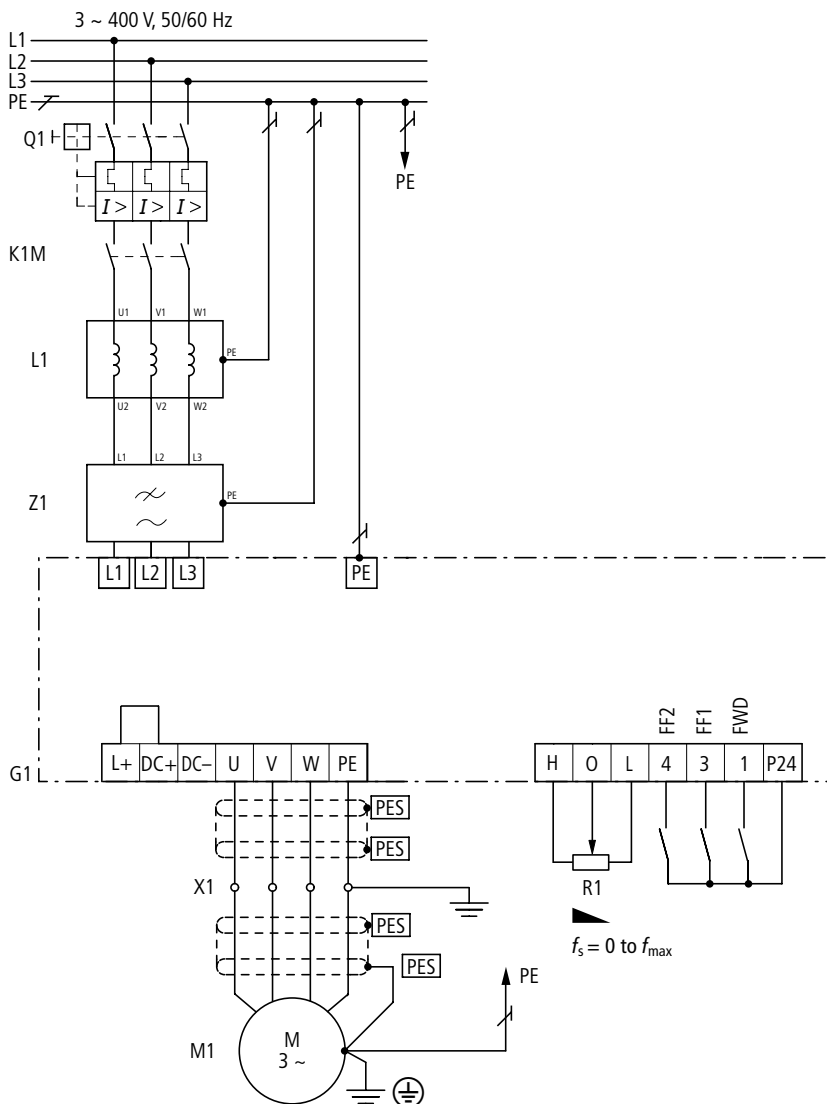

Motor: $P = 0.75 \text{ kW}$

Mains: 3/N/PE 400 V, 50/60 Hz

EMC-conformant connection examples: power section

The 0.75 kW motor described below can be delta-connected to a single-phase 230 V mains (version A) or star-connected to a 400 V mains.

Depending on the mains voltage, a DF5-322 frequency inverter is selected for 230 V single-phase AC, or a DF5-340 for 400 V 3-phase AC, together with the corresponding accessories.

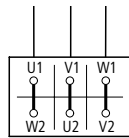
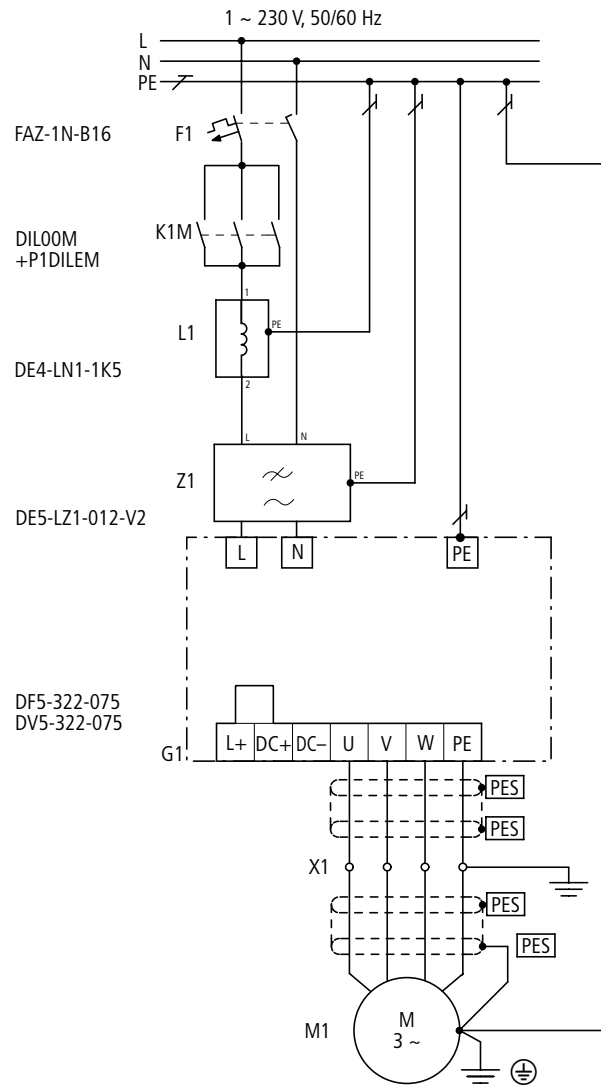

Δ
230 V
4 A
0.75 kW

230 Δ / 400 Υ V		4.0 / 2.3 A	
S1 0,75 kW		cos φ 0.67	
1410 rpm		50 Hz	

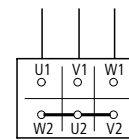
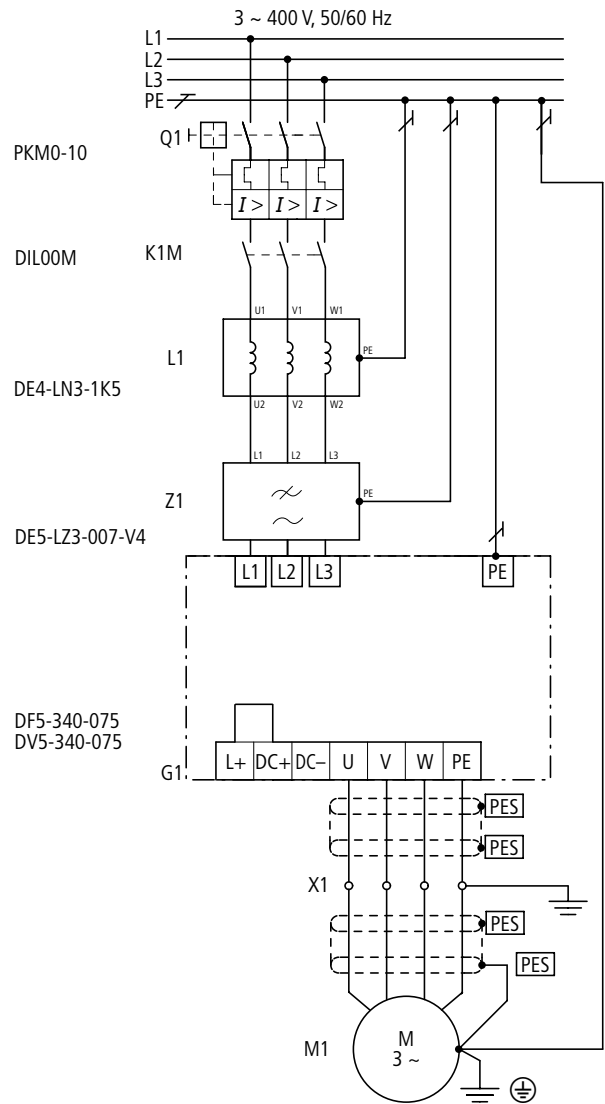

Υ
400 V
2.3 A
0.75 kW



Moeller HPL0211-2004/2005

DV5-340-... vector frequency inverters with EMC-conformant connection

Actuation

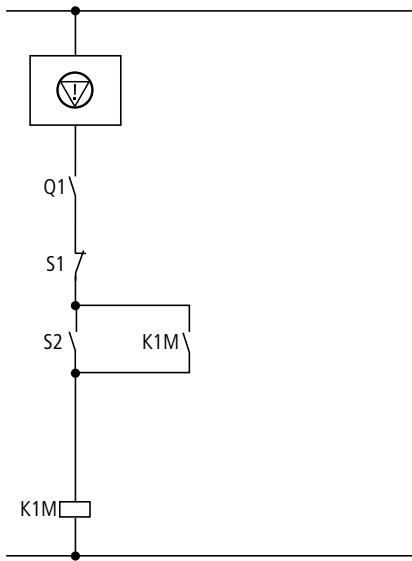

Example

Reference input from potentiometer R1 (f_s) and fixed frequency (f_1, f_2, f_3) through terminals 3 and 4 with internal control voltage
 Enable (START/STOP) and selection of rotating direction through terminal 1

- Emergency-Stop circuit
- S1: OFF
- S2: ON
- K1M: Mains contactor
- Z1: Radio interference suppression filter
- Q1: Line protection
- PES: PE connection of cable screen
- M1: 400 V 3-phase motor

- FWD: Clockwise rotating field enable, reference frequency f_s
- FF1: Fixed frequency f_1
- FF2: Fixed frequency f_2
- FF1+FF2: Fixed frequency f_3

Wiring

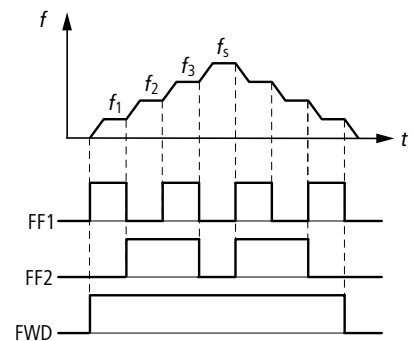
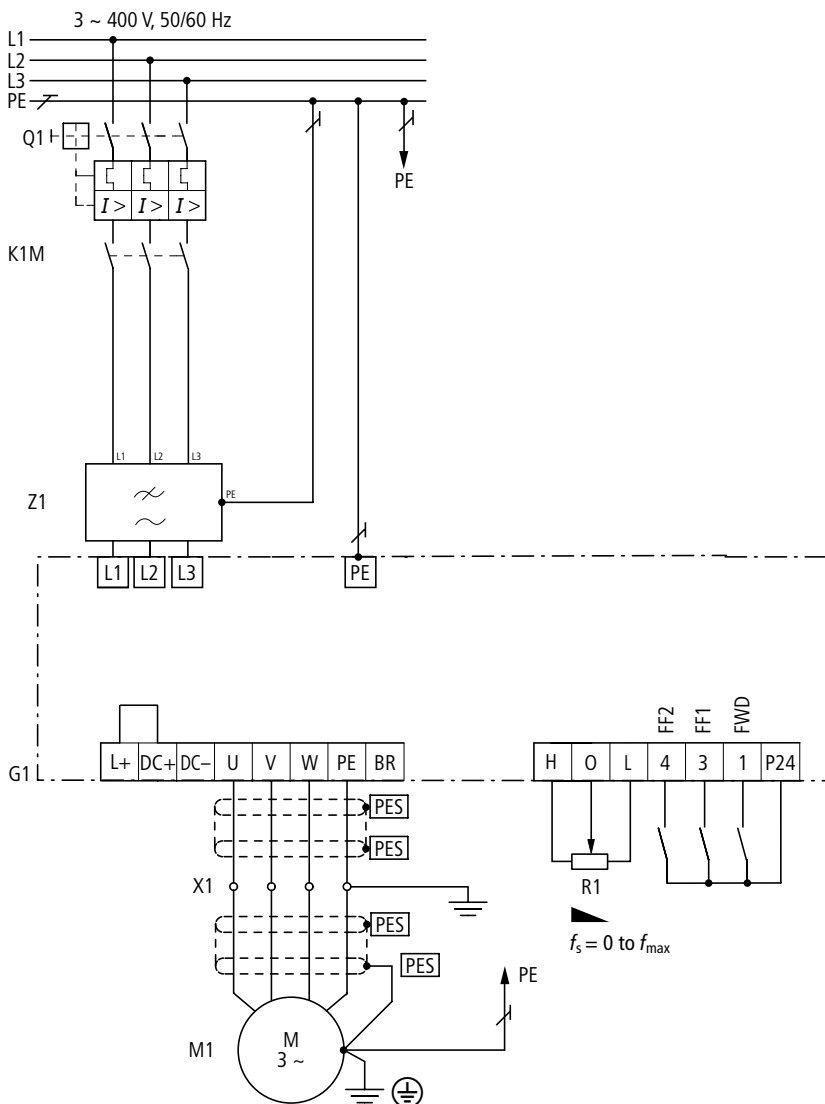

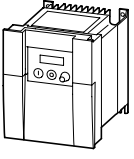
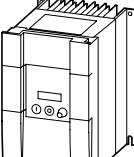
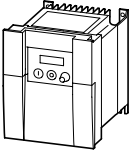
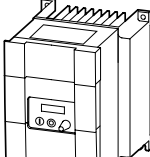
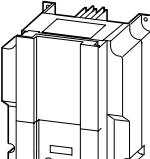
	Rated voltage	Max. rated operational current I_e A	Rated power of motors		Type Article no.	Price See Price List	Std. pack	
	U_e		At 230 V 3-phase AC	At 400 V 3-phase AC				
	V		P kW	P kW				
Frequency inverter 0.18 kW to 2.2 kW at 230 V								
	180 – 252 V 1-phase AC ± 0 %	1.4	0.18	–	DF5-322-018 231349	1 off		
	180 – 252 V 3-phase AC ± 0 %	2.6	0.37	–	DF5-322-037 231350			
	3	0.55	–	DF5-322-055 231351				
	4	0.75	–	DF5-322-075 231352				
	5	1.1	–	DF5-322-1K1 231353				
	7.1	1.5	–	DF5-322-1K5 231354				
	10	2.2	–	DF5-322-2K2 231355				
	Frequency inverters, 0.37 kW to 7.5 kW at 400 V							
	342 – 506 V 3-phase AC ± 0 %	1.5	–	0.37	DF5-340-037 231356		1 off	
	2.5	–	0.75	DF5-340-075 231357				
	3.8	–	1.5	DF5-340-1K5 231358				
	5.5	–	2.2	DF5-340-2K2 231359				
	7.8	–	3	DF5-340-3K0 231360				
	8.6	–	4	DF5-340-4K0 231362				
	13	–	5.5	DF5-340-5K5 231364				
	16	–	7.5	DF5-340-7K5 231365				

Notes
¹⁾ Rated operational current at an operating frequency of 5 kHz and an ambient temperature of +40 °C.

Moeller HPL0211-2004/2005

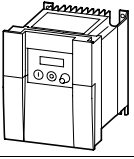
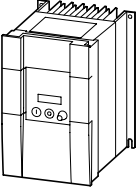
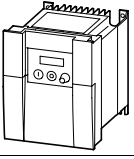
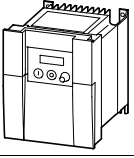
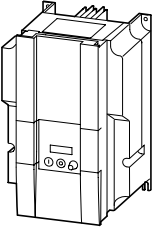
	Rated voltage	Max. rated operational current	Rated power of motors		Type Article no.	Price See Price List	Std. pack
	U_e	I_e	At 230 V 3-phase AC	At 400 V 3-phase AC			
	V	A	P kW	P kW			
Vector frequency inverters, 0.18 kW to 2.2 kW at 230 V							
	180 – 252 V 1-phase AC ± 0 %	1.4	0.18	–	DV5-322-018 231366	1 off	
	180 – 252 V 3-phase AC ± 0 %	2.6	0.37	–	DV5-322-037 231367		
	3	0.55	–	DV5-322-055 231368			
	4	0.75	–	DV5-322-075 231369			
	5	1.1	–	DV5-322-1K1 231370			
	8	1.5	–	DV5-322-1K5 231371			
	11	2.2	–	DV5-322-2K2 231372			
Vector frequency inverters, 0.37 kW to 7.5 kW at 400 V							
	342 – 506 V 3-phase AC ± 0 %	1.5	–	0.37	DV5-340-037 231373	1 off	
	2.5	–	0.75	DV5-340-075 231374			
	3.8	–	1.5	DV5-340-1K5 231375			
	5.5	–	2.2	DV5-340-2K2 231376			
	7.8	–	3	DV5-340-3K0 231380			
	8.6	–	4	DV5-340-4K0 231381			
	13	–	5.5	DV5-340-5K5 231382			
	16	–	7.5	DV5-340-7K5 231383			

Notes

²⁾ Rated operational current at an operating frequency of 5 kHz and an ambient temperature of +40 °C.

DF5, DF6 frequency inverters
DV5, DV6 vector frequency inverters



Moeller HPL0211-2004/2005

		DF5-322-018	DF5-322-037	DF5-322-055
General				
Standards		EN 50178, IEC 61800-3, EN 61800-3 incl. A11		
Ambient temperature				
Operating temperature	°C	10 to +40 at rated current I_e without derating, up to 50 at a reduced pulse frequency of 2 kHz and output current reduced to 80 % I_e		
Storage, transport	°C	-25 – +70		
Mechanical shock resistance		Vibration and impact, max. 5.9 m/s ² (0.6 g) at 10 to 55 Hz		
Pollution degree		VDE 0110 Part 2, pollution degree 2		
Climatic proofing		Class 3K3 according to EN 50178 (non-condensing, average relative humidity 20 to 90 %)		
Altitude	m	0 – 1000 above sea level		
Mounting position		Vertically suspended		
Free surrounding areas		100 mm above and below device		
Emitted interference		IEC/EN 61800-3 (EN 55011 group 1 class B)		
Noise immunity		IEC/EN 61800-3, industrial environment		
Insulation resistance		Overvoltage category III according to VDE 0110		
Leakage current to PE	mA	> 3.5 (according to EN 50178)		
Degree of protection		IP 20		
Contact protection		Finger and back-of-hand proof (BGV A2)		
Protective isolation from switching circuitry		Safe isolation from the mains. Double basic isolation (according to EN 50178)		
Protective measures		Overcurrent, earth fault, overvoltage, undervoltage, overload, overtemperature, electronic overload protection: I^2t monitoring and PTC input (thermistor or thermostat)		
Heat dissipation at rated operational current I_e	W	17	29	32
Dimensions (w × h × d)	mm	88.5 × 126 × 117	88.5 × 126 × 117	118 × 136 × 140
Weight	kg	0.85	0.85	1.3
Power section				
Rated operational voltage	V AC	230	230	230
Rated voltage	U_e V	1 AC 180 – 252 V ± 0 %; 3 AC 180 – 252 V ± 0 %		
Supply frequency	Hz	50/60 (47 -0 % to 63 +0 %)		
Mains current				
$U_l = 230$ V AC single-phase	I A	3.1	5.8	6.7
$U_l = 230$ V AC three-phase	I A	1.8	3.4	3.9
Alternative DC supply	U_{DC} V DC	200 – 365	200 – 365	200 – 365
Modulation method		Sine-wave pulse-width modulation (PWM), U/f characteristic control		
Switching frequency		5 kHz, adjustable from 0.5 to 16 kHz		
Output voltage	V	3 AC U_e	3 AC U_e	3 AC U_e
Output frequency	Hz	0.5 – 50, max. 360	0.5 – 50, max. 360	0.5 – 50, max. 360
Frequency resolution	kHz	0.1, with digital setpoint values/maximum frequency/1000 with analog setpoint values		
Frequency error threshold at 20 °C ± 10 K		±0.01 % of maximum frequency for digital reference values, ±0.2 % of maximum frequency for analog reference values		
Max. rated operational current	I_e A	1.4	2.6	3
Permissible overcurrent		150 % for 60 s, every 600 s	150 % for 60 s, every 600 s	150 % for 60 s, every 600 s
Torque during start		From 6 Hz 100 % or higher with torque boost activated		
Apparent power at 240 V	kVA	0.5	1	1.2
Standard operation at 150 % overload Assigned motor rating (4-pole ASM)				
230 V	kW	0.18	0.37	0.55
240 V	HP	¼	½	¾

Notes

If the frequency inverter is to be installed in an enclosure, control panel or similar housing, the ambient temperature T_a is taken to be the temperature inside this enclosure or control panel. All rating data of the power section is based on a switching frequency of 5 kHz (default setting) and an ambient temperature of +40 °C, for operation of a four-pole three-phase asynchronous motor.

Moeller HPL0211-2004/2005

DF5-322-075	DF5-322-1K1	DF5-322-1K5	DF5-322-2K2
EN 50178, IEC 61800-3, EN 61800-3 incl. A11			
10 to +40 at rated current I_e without derating, up to 50 at a reduced pulse frequency of 2 kHz and output current reduced to 80 % I_e			
-25 – +70			
Vibration and impact, max. 5.9 m/s ² (0.6 g) at 10 to 55 Hz			
VDE 0110 Part 2, pollution degree 2			
Class 3K3 according to EN 50178 (non-condensing, average relative humidity 20 to 90 %)			
0 – 1000 above sea level			
Vertically suspended			
100 mm above and below device			
IEC/EN 61800-3 (EN 55011 group 1 class B)			
IEC/EN 61800-3, industrial environment			
Overvoltage category III according to VDE 0110			
> 3.5 (according to EN 50178)			
IP 20			
Finger and back-of-hand proof (BGV A2)			
Safe isolation from the mains. Double basic isolation (according to EN 50178)			
Overcurrent, earth fault, overvoltage, undervoltage, overload, overtemperature, electronic overload protection: I^2t monitoring and PTC input (thermistor or thermostat)			
41	51	70	97
118 × 136 × 140	140 × 184.5 × 164	140 × 184.5 × 164	140 × 184.5 × 175
1.3	2.2	2.2	2.8
Power section			
230	230	230	230
1 AC 180 – 252 V ± 0 %; 3 AC 180 – 252 V ± 0 %			
50/60 (47 -0 % to 63 +0 %)			
Mains current			
9	11.2	16	22.5
5.2	6.5	9.3	13
200 – 365	200 – 365	200 – 365	200 – 365
Sine-wave pulse-width modulation (PWM), U/f characteristic control			
5 kHz, adjustable from 0.5 to 16 kHz			
3 AC U_e	3 AC U_e	3 AC U_e	3 AC U_e
0.5 – 50, max. 360	0.5 – 50, max. 360	0.5 – 50, max. 360	0.5 – 50, max. 360
0.1, with digital setpoint values/maximum frequency/1000 with analog setpoint values			
±0.01 % of maximum frequency for digital reference values, ±0.2 % of maximum frequency for analog reference values			
4	5	7.1	10
150 % for 60 s, every 600 s	150 % for 60 s, every 600 s	150 % for 60 s, every 600 s	150 % for 60 s, every 600 s
From 6 Hz 100 % or higher with torque boost activated			
1.6	2	2.9	4.1
Standard operation at 150 % overload Assigned motor rating (4-pole ASM)			
0.75	1.1	1.5	2.2
1	½	2	3



Moeller HPL0211-2004/2005

		DF5-322-018	DF5-322-037	DF5-322-055
Control circuit				
Relays		1 × changeover contact, 230 V AC/0.2 A inductive load/2.5 A resistive load or 24 V DC/0.7 A inductive load/3 A resistive load		
Serial interface		RS 422	RS 422	RS 422
Control voltage				
Output setpoint voltage	V	+10 DC, 10 mA	+10 DC, 10 mA	+10 DC, 10 mA
Output control voltage	V	+24 DC, 30 mA	+24 DC, 30 mA	+24 DC, 30 mA
Parameterization				
1 × parameter set (online/offline parameterization), parameter protection (programmable)				
Inputs				
Digital (configurable)		5 × +24 V DC	5 × +24 V DC	5 × +24 V DC
Analog	Number	2 × 0 – +10 V DC (input impedance 10 kΩ, 4 – 20 mA (load impedance 250 Ω))		
Outputs				
Digital		2 × 24 V DC transistor (open-collector, configurable)		
Analog (configurable)		1 × 0 – +10 V DC, 1 mA	1 × 0 – +10 V DC, 1 mA	1 × 0 – +10 V DC, 1 mA
Terminal capacities				
Power cables	mm ²	1.5	1.5	1.5
	AWG	16	16	16
Relay connection	mm ²	1.5	1.5	1.5
	AWG	16 – 6	16 – 6	16 – 6
Control circuit	mm ²	1.5	1.5	1.5
	AWG	16 – 6	16 – 6	16 – 6

Notes

If the frequency inverter is to be installed in an enclosure, control panel or similar housing, the ambient temperature T_a is taken to be the temperature inside this enclosure or control panel. All rating data of the power section is based on a switching frequency of 5 kHz (default setting) and an ambient temperature of +40 °C, for operation of a four-pole three-phase asynchronous motor.

Moeller HPL0211-2004/2005

DF5-322-075	DF5-322-1K1	DF5-322-1K5	DF5-322-2K2
1 × changeover contact, 230 V AC/0.2 A inductive load/2.5 A resistive load or 24 V DC/0.7 A inductive load/3 A resistive load			
RS 422	RS 422	RS 422	RS 422
+10 DC, 10 mA	+10 DC, 10 mA	+10 DC, 10 mA	+10 DC, 10 mA
+24 DC, 30 mA	+24 DC, 30 mA	+24 DC, 30 mA	+24 DC, 30 mA
1 × parameter set (online/offline parameterization), parameter protection (programmable)			
Inputs			
5 × +24 V DC	5 × +24 V DC	5 × +24 V DC	5 × +24 V DC
2 × 0 – +10 V DC (input impedance 10 kΩ, 4 – 20 mA (load impedance 250 Ω))			
Outputs			
2 × 24 V DC transistor (open-collector, configurable)			
1 × 0 – +10 V DC, 1 mA	1 × 0 – +10 V DC, 1 mA	1 × 0 – +10 V DC, 1 mA	1 × 0 – +10 V DC, 1 mA
Terminal capacities			
2.5	2.5	4	4
14	14	12	12
1.5	1.5	1.5	1.5
16 – 6	16 – 6	16 – 6	16 – 6
1.5	1.5	1.5	1.5
16 – 6	16 – 6	16 – 6	16 – 6

DF5, DF6 frequency inverters
DV5, DV6 vector frequency inverters

DF5, DF6 frequency inverters
DV5, DV6 vector frequency inverters



Moeller HPL0211-2004/2005

		DF5-340-037	DF5-340-075	DF5-340-1K5
General				
Standards		EN 50178, IEC 61800-3, EN 61800-3 incl. A11		
Ambient temperature				
Operating temperature	°C	-10 to +40 at rated current I_e without derating, up to 50 at a reduced pulse frequency of 2 kHz and output current reduced to 80 % I_e		
Storage, transport	°C	-25 – +70		
Mechanical shock resistance		Vibration and impact, max. 5.9 m/s ² (0.6 g) at 10 to 55 Hz		
Pollution degree		VDE 0110 Part 2, pollution degree 2		
Climatic proofing		Class 3K3 according to EN 50178 (non-condensing, average relative humidity 20 to 90 %)		
Altitude	m	0 – 1000 above sea level		
Mounting position		Vertically suspended		
Free surrounding areas		100 mm above and below device		
Emitted interference		IEC/EN 61800-3 (EN 55011 group 1 class B)		
Noise immunity		IEC/EN 61800-3, industrial environment		
Insulation resistance		Overvoltage category III according to VDE 0110		
Leakage current to PE	mA	> 3.5 (according to EN 50178)		
Degree of protection		IP 20		
Contact protection		Finger and back-of-hand proof (BGV A2)		
Protective isolation from switching circuitry		Safe isolation from the mains. Double basic isolation (according to EN 50178)		
Protective measures		Overcurrent, earth fault, overvoltage, undervoltage, overload, overtemperature, electronic overload protection: I^2t monitoring and PTC input (thermistor or thermostat)		
Heat dissipation at rated operational current I_e	W	32	44	65
Dimensions (w × h × d)	mm	118 × 136 × 140	118 × 136 × 167	118 × 136 × 167
Weight	kg	1.3	1.7	1.7
Power section				
Rated operational voltage	V AC	400	400	400
Rated voltage	U_e V	3 AC 342 – 506 V ± 0 %		
Supply frequency	Hz	50/60 (47 -0 % to 63 +0 %)		
Mains current				
$U_i = 400$ V AC three-phase	I A	2	3.3	5
Alternative DC supply	U_{DC} V DC	415 – 730	415 – 730	415 – 730
Modulation method		Sine-wave pulse-width modulation (PWM), U/f characteristic control		
Switching frequency		5 kHz, adjustable from 0.5 to 16 kHz		
Output voltage	V	3 AC U_e	3 AC U_e	3 AC U_e
Output frequency	Hz	0.5 – 50, max. 360	0.5 – 50, max. 360	0.5 – 50, max. 360
Frequency resolution	Hz	0.1, with digital setpoint values/maximum frequency/1000 with analog setpoint values		
Frequency error threshold at 20 °C ± 10 K		±0.01 % of maximum frequency for digital reference values, ±0.2 % of maximum frequency for analog reference values		
Max. rated operational current	I_e A	1.5	2.5	3.8
Permissible overcurrent		150 % for 60 s, every 600 s	150 % for 60 s, every 600 s	150 % for 60 s, every 600 s
Torque during start		From 6 Hz 100 % or higher with torque boost activated		
Apparent power at 460 V	kVA	1.1	1.9	3
Standard operation at 150 % overload Assigned motor rating (4-pole ASM)				
400 V	kW	0.37	0.75	1.5
460 V	HP	½	1	2

Notes

If the frequency inverter is to be installed in an enclosure, control panel or similar housing, the ambient temperature T_a is taken to be the temperature inside this enclosure or control panel. All rating data of the power section is based on a switching frequency of 5 kHz (default setting) and an ambient temperature of +40 °C, for operation of a four-pole three-phase asynchronous motor.

Moeller HPL0211-2004/2005

		DF5-340-2K2	DF5-340-3K0	DF5-340-4K0	DF5-340-5K5	DF5-340-7K5
General						
Standards		EN 50178, IEC 61800-3, EN 61800-3 incl. A11				
Ambient temperature						
Operating temperature	°C	-10 to +40 at rated current I_e without derating, up to 50 at a reduced pulse frequency of 2 kHz and output current reduced to 80 % I_e				
Storage, transport	°C	-25 – +70				
Mechanical shock resistance		Vibration and impact, max. 5.9 m/s ² (0.6 g) at 10 to 55 Hz				
Pollution degree		VDE 0110 Part 2, pollution degree 2				
Climatic proofing		Class 3K3 according to EN 50178 (non-condensing, average relative humidity 20 to 90 %)				
Altitude	m	0 – 1000 above sea level				
Mounting position		Vertically suspended				
Free surrounding areas		100 mm above and below device				
Emitted interference		IEC/EN 61800-3 (EN 55011 group 1 class B)				
Noise immunity		IEC/EN 61800-3, industrial environment				
Insulation resistance		Overvoltage category III according to VDE 0110				
Leakage current to PE	mA	> 3.5 (according to EN 50178)				
Degree of protection		IP 20				
Contact protection		Finger and back-of-hand proof (BGV A2)				
Protective isolation from switching circuitry		Safe isolation from the mains. Double basic isolation (according to EN 50178)				
Protective measures		Overcurrent, earth fault, overvoltage, undervoltage, overload, overtemperature, electronic overload protection: I^2t monitoring and PTC input (thermistor or thermostat)				
Heat dissipation at rated operational current I_e	W	92	138	151	219	261
Dimensions (w × h × d)	mm	140 × 184.5 × 175	140 × 184.5 × 175	140 × 184.5 × 175	182 × 260 × 177	182 × 260 × 177
Weight	kg	2.8	2.8	2.8	5.5	5.7
Power section						
Rated operational voltage	V AC	400	400	400	400	400
Rated voltage	U_e V	3 AC 342 – 506 V ± 0 %				
Supply frequency	Hz	50/60 (47 -0 % to 63 +0 %)				
Mains current						
$U_i = 400$ V AC three-phase	I A	7	10	11	16.5	20
Alternative DC supply	U_{DC} V DC	415 – 730	415 – 730	415 – 730	415 – 730	415 – 730
Modulation method		Sine-wave pulse-width modulation (PWM), U/f characteristic control				
Switching frequency		5 kHz, adjustable from 0.5 to 16 kHz				
Output voltage	V	3 AC U_e	3 AC U_e	3 AC U_e	3 AC U_e	3 AC U_e
Output frequency	Hz	0.5 – 50, max. 360	0.5 – 50, max. 360	0.5 – 50, max. 360	0.5 – 50, max. 360	0.5 – 50, max. 360
Frequency resolution	Hz	0.1, with digital setpoint values/maximum frequency/1000 with analog setpoint values				
Frequency error threshold at 20 °C ± 10 K		±0.01 % of maximum frequency for digital reference values, ±0.2 % of maximum frequency for analog reference values				
Max. rated operational current	I_e A	5.5	7.8	8.6	13	16
Permissible overcurrent		150 % for 60 s, every 600 s	150 % for 60 s, every 600 s	150 % for 60 s, every 600 s	150 % for 60 s, every 600 s	150 % for 60 s, every 600 s
Torque during start		From 6 Hz 100 % or higher with torque boost activated				
Apparent power at 460 V	kVA	4.3	6.2	6.8	10.3	12.7
Standard operation at 150 % overload Assigned motor rating (4-pole ASM)						
400 V	kW	2.2	3	4	5.5	7.5
460 V	HP	3	4	5	7 ½	10



Moeller HPL0211-2004/2005

		DF5-340-037	DF5-340-075	DF5-340-1K5
Control circuit				
Relays		1 × changeover contact, 230 V AC/0.2 A inductive load/2.5 A resistive load or 24 V DC/0.7 A inductive load/3 A resistive load		
Serial interface		RS 422	RS 422	RS 422
Control voltage				
Output setpoint voltage	V	+10 DC, 10 mA	+10 DC, 10 mA	+10 DC, 10 mA
Output control voltage	V	+24 DC, 30 mA	+24 DC, 30 mA	+24 DC, 30 mA
Parameterization				
1 parameter set (online/offline parameterization), parameter protection (programmable)				
Inputs				
Digital (configurable)		5 × +24 V DC	5 × +24 V DC	5 × +24 V DC
Analog	Number	2 × 0 – +10 V DC (input impedance 10 kΩ, 4 – 20 mA (load impedance 250 Ω))		
Outputs				
Digital		2 × 24 V DC transistor (open-collector, configurable)		
Analog (configurable)		1 × 0 – +10 V DC, 1 mA	1 × 0 – +10 V DC, 1 mA	1 × 0 – +10 V DC, 1 mA
Terminal capacities				
Power cables	mm ²	1.5	1.5	1.5
	AWG	16	16	16
Relay connection	mm ²	1.5	1.5	1.5
	AWG	16 – 6	16 – 6	16 – 6
Control circuit	mm ²	1.5	1.5	1.5
	AWG	16 – 6	16 – 6	16 – 6

Notes
If the frequency inverter is to be installed in an enclosure, control panel or similar housing, the ambient temperature T_a is taken to be the temperature inside this enclosure or control panel. All rating data of the power section is based on a switching frequency of 5 kHz (default setting) and an ambient temperature of +40 °C, for operation of a four-pole three-phase asynchronous motor.

Moeller HPL0211-2004/2005

DF5-340-2K2	DF5-340-3K0	DF5-340-4K0	DF5-340-5K5	DF5-340-7K5
1 × changeover contact, 230 V AC/0.2 A inductive load/2.5 A resistive load or 24 V DC/0.7 A inductive load/3 A resistive load				
RS 422	RS 422	RS 422	RS 422	RS 422
+10 DC, 10 mA	+10 DC, 10 mA	+10 DC, 10 mA	+10 DC, 10 mA	+10 DC, 10 mA
+24 DC, 30 mA	+24 DC, 30 mA	+24 DC, 30 mA	+24 DC, 30 mA	+24 DC, 30 mA
1 parameter set (online/offline parameterization), parameter protection (programmable)				
Inputs				
5 × +24 V DC	5 × +24 V DC	5 × +24 V DC	5 × +24 V DC	5 × +24 V DC
2 × 0 – +10 V DC (input impedance 10 kΩ, 4 – 20 mA (load impedance 250 Ω))				
Outputs				
2 × 24 V DC transistor (open-collector, configurable)				
1 × 0 – +10 V DC, 1 mA	1 × 0 – +10 V DC, 1 mA	1 × 0 – +10 V DC, 1 mA	1 × 0 – +10 V DC, 1 mA	1 × 0 – +10 V DC, 1 mA
Terminal capacities				
2.5	2.5	4	4	4
14	14	12	12	12
1.5	1.5	1.5	1.5	1.5
16 – 6	16 – 6	16 – 6	16 – 6	16 – 6
1.5	1.5	1.5	1.5	1.5
16 – 6	16 – 6	16 – 6	16 – 6	16 – 6

DF5, DF6 frequency inverters
DV5, DV6 vector frequency inverters

DF5, DF6 frequency inverters
DV5, DV6 vector frequency inverters



Moeller HPL0211-2004/2005

		DV5-322-018	DV5-322-037	DV5-322-055
General				
Standards		EN 50178, IEC 61800-3, EN 61800-3 incl. A11		
Ambient temperature				
Operating temperature	°C	-10 to +40 at rated current I_e without derating, up to 50 at a reduced pulse frequency of 2 kHz and output current reduced to 80 % I_e		
Storage, transport	°C	-25 – +70		
Mechanical shock resistance		Vibration and impact, max. 5.9 m/s ² (0.6 g) at 10 to 55 Hz		
Pollution degree		VDE 0110 Part 2, pollution degree 2		
Climatic proofing		Class 3K3 according to EN 50178 (non-condensing, average relative humidity 20 to 90 %)		
Altitude	m	0 – 1000 above sea level		
Mounting position		Vertically suspended		
Free surrounding areas		100 mm above and below device		
Emitted interference		IEC/EN 61800-3 (EN 55011 group 1 class B)		
Noise immunity		IEC/EN 61800-3, industrial environment		
Insulation resistance		Overvoltage category III according to VDE 0110		
Leakage current to PE	mA	> 3.5 (according to EN 50178)		
Degree of protection		IP 20		
Contact protection		Finger and back-of-hand proof (BGV A2)		
Protective isolation from switching circuitry		Safe isolation from the mains. Double basic isolation (according to EN 50178)		
Protective measures		Overcurrent, earth fault, overvoltage, undervoltage, overload, overtemperature, electronic overload protection: I^2t monitoring and PTC input (thermistor or thermostat)		
Heat dissipation at rated operational current I_e	W	19	29	32
Dimensions (w × h × d)	mm	88.5 × 136 × 103	88.5 × 136 × 117	88.5 × 136 × 117
Weight	kg	0.7	0.8	0.8
Power section				
Rated operational voltage	V AC	230	230	230
Rated voltage	U_e V	1 AC 180 – 252 V ± 0 %; 3 AC 180 – 252 V ± 0 %		
Supply frequency	Hz	50/60 (47 -0 % to 63 +0 %)		
Mains current				
$U_i = 230$ V AC single-phase	I A	3.5	5.8	6.7
$U_i = 230$ V AC three-phase	I A	1.8	3.4	3.9
Alternative DC supply	U_{DC} V DC	200 – 365		
Modulation method		Sensorless vector control, pulse width modulation (PWM)		
Switching frequency		5 kHz, adjustable from 0.5 to 16 kHz		
Output voltage	V	3 AC U_e	3 AC U_e	3 AC U_e
Output frequency	Hz	0.5 – 50, max. 360	0.5 – 50, max. 360	0.5 – 50, max. 360
Frequency resolution	Hz	0.1, with digital setpoint values/maximum frequency/1000 with analog setpoint values		
Frequency error threshold at 20 °C ± 10 K		±0.01 % of maximum frequency for digital reference values, ±0.2 % of maximum frequency for analog reference values		
Max. rated operational current	I_e A	1.4	2.6	3
Permissible overcurrent		150 % for 60 s, every 600 s	150 % for 60 s, every 600 s	150 % for 60 s, every 600 s
Torque during start		From 1 Hz: 200 % with sensorless vector control		
Apparent power at 240 V	kVA	0.6	1	1.2
Standard operation at 150 % overload Assigned motor rating (4-pole ASM)				
230 V	kW	0.18	0.37	0.55
240 V	HP	¼	½	¾
Brake transistor				
Switching threshold	U_{DC} V DC	370	370	370
Resistance R_B at 100 % DF	R Ω	130	130	130
Lowest impedance	R_B Ω	100	100	100
Max. duty factor (DF) at lowest impedance R_B	% DF	80	80	80

Notes

If the frequency inverter is to be installed in an enclosure, control panel or similar housing, the ambient temperature T_a is taken to be the temperature inside this enclosure or control panel. All rating data of the power section is based on a switching frequency of 5 kHz (default setting) and an ambient temperature of +40 °C, for operation of a four-pole three-phase asynchronous motor.

Moeller HPL0211-2004/2005

		DV5-322-075	DV5-322-1K1	DV5-322-1K5	DV5-322-2K2
General					
Standards		EN 50178, IEC 61800-3, EN 61800-3 incl. A11			
Ambient temperature					
Operating temperature	°C	-10 to +40 at rated current I_e without derating, up to 50 at a reduced pulse frequency of 2 kHz and output current reduced to 80 % I_e			
Storage, transport	°C	-25 – +70			
Mechanical shock resistance		Vibration and impact, max. 5.9 m/s ² (0.6 g) at 10 to 55 Hz			
Pollution degree		VDE 0110 Part 2, pollution degree 2			
Climatic proofing		Class 3K3 according to EN 50178 (non-condensing, average relative humidity 20 to 90 %)			
Altitude	m	0 – 1000 above sea level			
Mounting position		Vertically suspended			
Free surrounding areas		100 mm above and below device			
Emitted interference		IEC/EN 61800-3 (EN 55011 group 1 class B)			
Noise immunity		IEC/EN 61800-3, industrial environment			
Insulation resistance		Overvoltage category III according to VDE 0110			
Leakage current to PE	mA	> 3.5 (according to EN 50178)			
Degree of protection		IP 20			
Contact protection		Finger and back-of-hand proof (BGV A2)			
Protective isolation from switching circuitry		Safe isolation from the mains. Double basic isolation (according to EN 50178)			
Protective measures		Overcurrent, earth fault, overvoltage, undervoltage, overload, overtemperature, electronic overload protection: I^2t monitoring and PTC input (thermistor or thermostat)			
Heat dissipation at rated operational current I_e	W	41	51	79	107
Dimensions (w × h × d)	mm	118 × 136 × 140	118 × 136 × 140	140 × 184.5 × 175	140 × 184.5 × 175
Weight	kg	1.3	1.3	2.2	2.8
Power section					
Rated operational voltage	V AC	230	230	230	230
Rated voltage	U_e V	1 AC 180 – 252 V ± 0 %; 3 AC 180 – 252 V ± 0 %			
Supply frequency	Hz	50/60 (47 -0 % to 63 +0 %)			
Mains current					
$U_i = 230$ V AC single-phase	I A	9	11.2	17.5	24
$U_i = 230$ V AC three-phase	I A	5.2	6.5	10	14
Alternative DC supply	U_{DC} V DC	200 – 365			
Modulation method		Sensorless vector control, pulse width modulation (PWM)			
Switching frequency		5 kHz, adjustable from 0.5 to 16 kHz			
Output voltage	V	3 AC U_e	3 AC U_e	3 AC U_e	3 AC U_e
Output frequency	Hz	0.5 – 50, max. 360	0.5 – 50, max. 360	0.5 – 50, max. 360	0.5 – 50, max. 360
Frequency resolution	Hz	0.1, with digital setpoint values/maximum frequency/1000 with analog setpoint values			
Frequency error threshold at 20 °C ± 10 K		±0.01 % of maximum frequency for digital reference values, ±0.2 % of maximum frequency for analog reference values			
Max. rated operational current	I_e A	4	5	8	11
Permissible overcurrent		150 % for 60 s, every 600 s	150 % for 60 s, every 600 s	150 % for 60 s, every 600 s	150 % for 60 s, every 600 s
Torque during start		From 1 Hz: 200 % with sensorless vector control			
Apparent power at 240 V	kVA	1.6	2	3.3	4.5
Standard operation at 150 % overload Assigned motor rating (4-pole ASM)					
230 V	kW	0.75	1.1	1.5	2.2
240 V	HP	1	M 1	2	3
Brake transistor					
Switching threshold	U_{DC} V DC	370	370	370	370
Resistance R_B at 100 % DF	R Ω	90	90	50	35
Lowest impedance	R_B Ω	35	35	35	35
Max. duty factor (DF) at lowest impedance R_B	% DF	39	39	70	100

Notes

If the frequency inverter is to be installed in an enclosure, control panel or similar housing, the ambient temperature T_a is taken to be the temperature inside this enclosure or control panel. All rating data of the power section is based on a switching frequency of 5 kHz (default setting) and an ambient temperature of +40 °C, for operation of a four-pole three-phase asynchronous motor.



Moeller HPL0211-2004/2005

		DV5-322-018	DV5-322-037	DV5-322-055
Control circuit				
Relays		1 changeover contact, 230 V AC/0.2 A inductive load/2.5 A resistive load or 24 V DC/0.7 A inductive load/3 A resistive load		
Serial interface		RS 422	RS 422	RS 422
Control voltage				
	Output setpoint voltage	V	+10 DC, 10 mA	+10 DC, 10 mA
	Output control voltage	V	+24 DC, 30 mA	+24 DC, 30 mA
Parameterization		2 parameter sets (online/offline parameterization), parameter protection (programmable)		
Inputs				
	Digital (configurable)		6 × +24 V DC	6 × +24 V DC
	Analog	Number	2 × 0 – +10 V DC (input impedance 10 kΩ, 4 – 20 mA (load impedance 250 Ω))	
Outputs				
	Digital		2 × 24 V DC transistor (open-collector, configurable)	
	Analog (configurable)		1 × 0 – +10 V DC, 1 mA	1 × 0 – +10 V DC, 1 mA
Terminal capacities				
Power cables		mm ²	1.5	1.5
		AWG	16	16
Relay connection		mm ²	1.5	1.5
		AWG	6 – 1	6 – 1
Control circuit		mm ²	1.5	1.5
		AWG	6 – 1	6 – 1

Notes

If the frequency inverter is to be installed in an enclosure, control panel or similar housing, the ambient temperature T_a is taken to be the temperature inside this enclosure or control panel. All rating data of the power section is based on a switching frequency of 5 kHz (default setting) and an ambient temperature of +40 °C, for operation of a four-pole three-phase asynchronous motor.

Moeller HPL0211-2004/2005

DV5-322-075	DV5-322-1K1	DV5-322-1K5	DV5-322-2K2
1 changeover contact, 230 V AC/0.2 A inductive load/2.5 A resistive load or 24 V DC/0.7 A inductive load/3 A resistive load			
RS 422	RS 422	RS 422	RS 422
+10 DC, 10 mA	+10 DC, 10 mA	+10 DC, 10 mA	+10 DC, 10 mA
+24 DC, 30 mA	+24 DC, 30 mA	+24 DC, 30 mA	+24 DC, 30 mA
2 parameter sets (online/offline parameterization), parameter protection (programmable)			
Inputs			
6 × +24 V DC	6 × +24 V DC	6 × +24 V DC	6 × +24 V DC
2 × 0 – +10 V DC (input impedance 10 kΩ, 4 – 20 mA (load impedance 250 Ω))			
Outputs			
2 × 24 V DC transistor (open-collector, configurable)			
1 × 0 – +10 V DC, 1 mA	1 × 0 – +10 V DC, 1 mA	1 × 0 – +10 V DC, 1 mA	1 × 0 – +10 V DC, 1 mA
Terminal capacities			
2.5	2.5	4	4
14	14	12	12
1.5	1.5	1.5	1.5
6 – 1	6 – 1	6 – 1	6 – 1
1.5	1.5	1.5	1.5
6 – 1	6 – 1	6 – 1	6 – 1



Moeller HPL0211-2004/2005

		DV5-340-037	DV5-340-075	DV5-340-1K5
General				
Standards		EN 50178, IEC 61800-3, EN 61800-3 incl. A11		
Ambient temperature				
Operating temperature	°C	-10 to +40 at rated current I_e without derating, up to 50 at a reduced pulse frequency of 2 kHz and output current reduced to 80 % I_e		
Storage, transport	°C	-25 – +70		
Mechanical shock resistance		Vibration and impact, max. 5.9 m/s ² (0.6 g) at 10 to 55 Hz		
Pollution degree		VDE 0110 Part 2, pollution degree 2		
Climatic proofing		Class 3K3 according to EN 50178 (non-condensing, average relative humidity 20 to 90 %)		
Altitude	m	0 – 1000 above sea level		
Mounting position		Vertically suspended		
Free surrounding areas		100 mm above and below device		
Emitted interference		IEC/EN 61800-3 (EN 55011 group 1 class B)		
Noise immunity		IEC/EN 61800-3, industrial environment		
Insulation resistance		Overvoltage category III according to VDE 0110		
Leakage current to PE	mA	> 3.5 (according to EN 50178)		
Degree of protection		IP 20		
Contact protection		Finger and back-of-hand proof (BGV A2)		
Protective isolation from switching circuitry		Safe isolation from the mains. Double basic isolation (according to EN 50178)		
Protective measures		Overcurrent, earth fault, overvoltage, undervoltage, overload, overtemperature, electronic overload protection: I^2t monitoring and PTC input (thermistor or thermostat)		
Heat dissipation at rated operational current I_e	W	32	44	65
Dimensions (w × h × d)	mm	118 × 136 × 140	118 × 136 × 140	118 × 136 × 140
Weight	kg	1.3	1.7	1.7
Power section				
Rated operational voltage	V AC	400	400	400
Rated voltage	U_e V	3 AC 342 – 506 V ± 0 %	3 AC 342 – 506 V ± 0 %	3 AC 342 – 506 V ± 0 %
Supply frequency	Hz	50/60 (47 -0 % to 63 +0 %)	50/60 (47 -0 % to 63 +0 %)	50/60 (47 -0 % to 63 +0 %)
Mains current				
$U_i = 400$ V AC three-phase	I A	2	3.3	5
Alternative DC supply	U_{DC} V DC	415 – 730	415 – 730	415 – 730
Modulation method		Sensorless vector control, pulse width modulation (PWM)		
Switching frequency		5 kHz, adjustable from 0.5 to 16 kHz		
Output voltage	V	3 AC U_e	3 AC U_e	3 AC U_e
Output frequency	Hz	0.5 – 50, max. 360	0.5 – 50, max. 360	0.5 – 50, max. 360
Frequency resolution	Hz	0.1, with digital setpoint values/maximum frequency/1000 with analog setpoint values		
Frequency error threshold at 20 °C ± 10 K		±0.01 % of maximum frequency for digital reference values, ±0.2 % of maximum frequency for analog reference values		
Max. rated operational current	I_e A	1.5	2.5	3.8
Permissible overcurrent		150 % for 60 s, every 600 s	150 % for 60 s, every 600 s	150 % for 60 s, every 600 s
Torque during start		From 1 Hz: 200 % with sensorless vector control		
Apparent power at 460 V	kVA	1.1	1.9	2.9
Standard operation at 150 % overload Assigned motor rating (4-pole ASM)				
400 V	kW	0.37	0.75	1.5
460 V	HP	½	1	2
Brake transistor				
Switching threshold	U_{DC} V DC	740	740	740
Resistance R_B at 100 % DF	R Ω	500	300	200
Lowest impedance	R_B Ω	180	180	180
Max. duty factor (DF) at lowest impedance R_B	% DF	36	60	90

Notes

If the frequency inverter is to be installed in an enclosure, control panel or similar housing, the ambient temperature T_a is taken to be the temperature inside this enclosure or control panel. All rating data of the power section is based on a switching frequency of 5 kHz (default setting) and an ambient temperature of +40 °C, for operation of a four-pole three-phase asynchronous motor.

Moeller HPL0211-2004/2005

		DV5-340-2K2	DV5-340-3K0	DV5-340-4K0	DV5-340-5K5	DV5-340-7K5
General						
Standards		EN 50178, IEC 61800-3, EN 61800-3 incl. A11				
Ambient temperature						
Operating temperature	°C	-10 to +40 at rated current I_e without derating, up to 50 at a reduced pulse frequency of 2 kHz and output current reduced to 80 % I_e				
Storage, transport	°C	-25 – +70				
Mechanical shock resistance		Vibration and impact, max. 5.9 m/s ² (0.6 g) at 10 to 55 Hz				
Pollution degree		VDE 0110 Part 2, pollution degree 2				
Climatic proofing		Class 3K3 according to EN 50178 (non-condensing, average relative humidity 20 to 90 %)				
Altitude	m	0 – 1000 above sea level				
Mounting position		Vertically suspended				
Free surrounding areas		100 mm above and below device				
Emitted interference		IEC/EN 61800-3 (EN 55011 group 1 class B)				
Noise immunity		IEC/EN 61800-3, industrial environment				
Insulation resistance		Overvoltage category III according to VDE 0110				
Leakage current to PE	mA	> 3.5 (according to EN 50178)				
Degree of protection		IP 20				
Contact protection		Finger and back-of-hand proof (BGV A2)				
Protective isolation from switching circuitry		Safe isolation from the mains. Double basic isolation (according to EN 50178)				
Protective measures		Overcurrent, earth fault, overvoltage, undervoltage, overload, overtemperature, electronic overload protection: I^2t monitoring and PTC input (thermistor or thermostat)				
Heat dissipation at rated operational current I_e	W	92	138	151	219	261
Dimensions (w × h × d)	mm	118 × 136 × 140	140 × 184.5 × 175	140 × 184.5 × 175	182 × 260 × 177	182 × 260 × 177
Weight	kg	1.7	2.8	2.8	5.5	5.7
Power section						
Rated operational voltage	V AC	400	400	400	400	400
Rated voltage	U_e V	3 AC 342 – 506 V ± 0 %	3 AC 342 – 506 V ± 0 %	3 AC 342 – 506 V ± 0 %	3 AC 342 – 506 V ± 0 %	3 AC 342 – 506 V ± 0 %
Supply frequency	Hz	50/60 (47 -0 % to 63 +0 %)	50/60 (47 -0 % to 63 +0 %)	50/60 (47 -0 % to 63 +0 %)	50/60 (47 -0 % to 63 +0 %)	50/60 (47 -0 % to 63 +0 %)
Mains current						
$U_i = 400$ V AC three-phase	I A	7	10	11	16.5	20
Alternative DC supply	U_{DC} V DC	415 – 730	415 – 730	415 – 730	415 – 730	415 – 730
Modulation method		Sensorless vector control, pulse width modulation (PWM)				
Switching frequency		5 kHz, adjustable from 0.5 to 16 kHz				
Output voltage	V	3 AC U_e	3 AC U_e	3 AC U_e	3 AC U_e	3 AC U_e
Output frequency	Hz	0.5 – 50, max. 360	0.5 – 50, max. 360	0.5 – 50, max. 360	0.5 – 50, max. 360	0.5 – 50, max. 360
Frequency resolution	Hz	0.1, with digital setpoint values/maximum frequency/1000 with analog setpoint values				
Frequency error threshold at 20 °C ± 10 K		±0.01 % of maximum frequency for digital reference values, ±0.2 % of maximum frequency for analog reference values				
Max. rated operational current	I_e A	5.5	7.8	8.6	13	16
Permissible overcurrent		150 % for 60 s, every 600 s	150 % for 60 s, every 600 s	150 % for 60 s, every 600 s	150 % for 60 s, every 600 s	150 % for 60 s, every 600 s
Torque during start		From 1 Hz: 200 % with sensorless vector control				
Apparent power at 460 V	kVA	4.2	6.2	6.6	9.9	12.2
Standard operation at 150 % overload Assigned motor rating (4-pole ASM)						
400 V	kW	2.2	3	4	5.5	7.5
460 V	HP	3	4	5	7 ½	10
Brake transistor						
Switching threshold	U_{DC} V DC	740	740	740	740	740
Resistance R_B at 100 % DF	R Ω	150	100	100	70	70
Lowest impedance	R_B Ω	100	100	100	50	50
Max. duty factor (DF) at lowest impedance R_B	% DF	67	100	100	70	70



Moeller HPL0211-2004/2005

		DV5-340-037	DV5-340-075	DV5-340-1K5
Control circuit				
Relays		1 changeover contact, 230 V AC/0.2 A inductive load/2.5 A resistive load or 24 V DC/0.7 A inductive load/3 A resistive load		
Serial interface		RS 422	RS 422	RS 422
Control voltage				
Output setpoint voltage	V	+10 DC, 10 mA	+10 DC, 10 mA	+10 DC, 10 mA
Output control voltage	V	+24 DC, 30 mA	+24 DC, 30 mA	+24 DC, 30 mA
Parameterization				
2 × parameter sets (online/offline parameterization), parameter protection (programmable)				
Inputs				
Digital (configurable)		6 × +24 V DC	6 × +24 V DC	6 × +24 V DC
Analog	Number	2 × 0 – +10 V DC (input impedance 10 kΩ, 4 – 20 mA (load impedance 250 Ω))		
Outputs				
Digital		2 × 24 V DC transistor (open-collector, configurable)		
Analog (configurable)		1 × 0 – +10 V DC, 1 mA	1 × 0 – +10 V DC, 1 mA	1 × 0 – +10 V DC, 1 mA
Terminal capacities				
Power cables	mm ²	1.5	1.5	1.5
	AWG	16	16	16
Relay connection	mm ²	1.5	1.5	1.5
	AWG	6 – 1	6 – 1	6 – 1
Control circuit	mm ²	1.5	1.5	1.5
	AWG	6 – 1	6 – 1	6 – 1

Notes

If the frequency inverter is to be installed in an enclosure, control panel or similar housing, the ambient temperature T_a is taken to be the temperature inside this enclosure or control panel. All rating data of the power section is based on a switching frequency of 5 kHz (default setting) and an ambient temperature of +40 °C, for operation of a four-pole three-phase asynchronous motor.

Moeller HPL0211-2004/2005

DV5-340-2K2	DV5-340-3K0	DV5-340-4K0	DV5-340-5K5	DV5-340-7K5
1 changeover contact, 230 V AC/0.2 A inductive load/2.5 A resistive load or 24 V DC/0.7 A inductive load/3 A resistive load				
RS 422	RS 422	RS 422	RS 422	RS 422
+10 DC, 10 mA	+10 DC, 10 mA	+10 DC, 10 mA	+10 DC, 10 mA	+10 DC, 10 mA
+24 DC, 30 mA	+24 DC, 30 mA	+24 DC, 30 mA	+24 DC, 30 mA	+24 DC, 30 mA
2 × parameter sets (online/offline parameterization), parameter protection (programmable)				
Inputs				
6 × +24 V DC	6 × +24 V DC	6 × +24 V DC	6 × +24 V DC	6 × +24 V DC
2 × 0 – +10 V DC (input impedance 10 kΩ, 4 – 20 mA (load impedance 250 Ω))				
Outputs				
2 × 24 V DC transistor (open-collector, configurable)				
1 × 0 – +10 V DC, 1 mA	1 × 0 – +10 V DC, 1 mA	1 × 0 – +10 V DC, 1 mA	1 × 0 – +10 V DC, 1 mA	1 × 0 – +10 V DC, 1 mA
Terminal capacities				
2.5	2.5	4	4	4
14	14	12	12	12
1.5	1.5	1.5	1.5	1.5
6 – 1	6 – 1	6 – 1	6 – 1	6 – 1
1.5	1.5	1.5	1.5	1.5
6 – 1	6 – 1	6 – 1	6 – 1	6 – 1



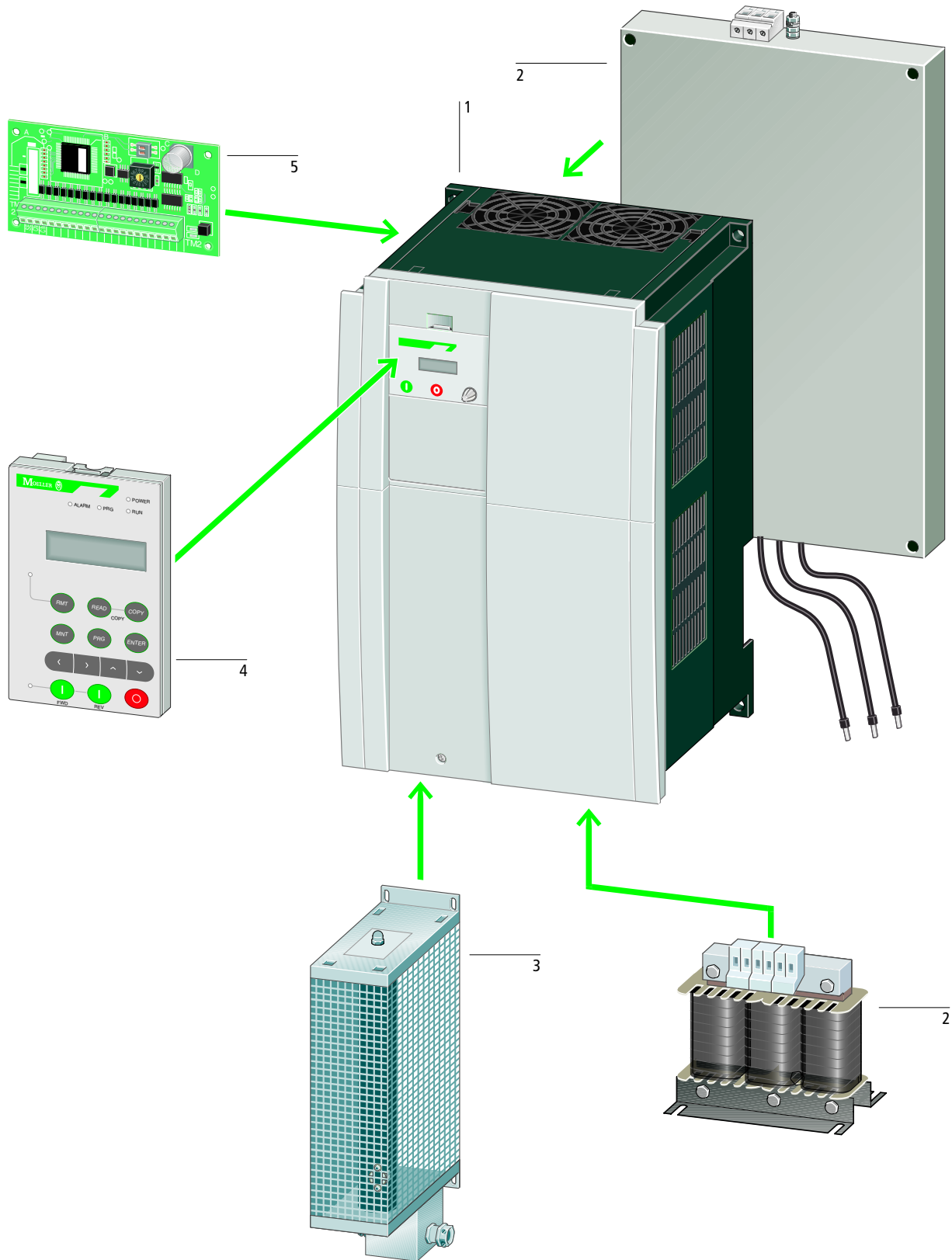

Moeller HPL0211-2004/2005

Basic units**Frequency inverters** 1

DF6-340-...

Mains: 400 V 3-phase

Motor rating
from 11 to 132 kW (400 V)

→ Page 18/40

Vector frequency inverters 1

DV6-340-...

Mains: 400 V 3-phase

Motor rating
from 0.75 to 132 kW (400 V)

→ Page 18/41

System accessories**Keypads** 4

DEX-KEY-10

External LCD keypad with memory
function

DE...-CBL-...

Connection cable for external display and
control units

→ Page 18/73

Communication modules 5

DE6-NET-DP

PROFIBUS DP interface

DE6-IOM-ENC

Encoder interfacing assembly

→ Page 18/73

Accessories**Radio interference suppression filter** 2

DE6-LZ3...

→ Page 18/59

Mains chokes 2

DEX-LN3-...

→ Page 18/75

Motor chokes 2

DEX-LM...

→ Page 18/76

Braking resistor 3

DE4-BR1-...

Enclosed (IP 20) high-capacity resistors
with temperature switch, for connecting to
the DV6's braking transistor

→ Page 18/77





Application

The DF6 frequency inverters provide economic speed control of three-phase motors in standard applications with square-law load characteristics (pumps, fans). The assigned performance range for four-pole three-phase asynchronous motors ranges from 11 kW to 132 kW at 400 V. The DF6 can be used as a stand-alone drive or incorporated in automation systems. With its function-generator *U/f* (voltage/frequency) control, it can be used in a wide range of applications, from pump and fan drives, through heating and air conditioning, to all areas of process control with rate regulation.

Features

- Compact construction
- Plug-in keypad (external installation possible) with four-character seven-segment display, six function keys and a setpoint value potentiometer
- RS 485 and RS 422 serial interface
- Six digital inputs (24 V DC)
- Three analog inputs (0 to +10 V, ± 10 V, 4 to 20 mA)
- Three relays (a changeover contact, two make contacts: 24 V DC/230 V AC)
- Thermistor input
- Bus interface (PROFIBUS DP) can be integrated.
- Conformance to global standards CE, UL, cUL, CSA and cTick

Function

Comprehensive protective functions guarantee safe operation and protect frequency inverters and motors:

- Overcurrent, earth fault
- Overload, electronic motor protection
- Overtemperature
- Overvoltage, undervoltage
- Phase failure

Two parameter sets with comprehensive functions:

- PID controllers
- Automatic energy saving mode
- Motor synchronization and flying restart circuit
- User macro storage
- Automatic restart after a power failure
- Electronic motor potentiometer function
- 16 fixed frequencies
- Min./max. frequency limitation

Documentation

Each DF6 frequency inverter is supplied with a sheet (AWA) of mounting and connection instructions and a CD.

The AWA contains a short description with illustrations and information about correct handling, installation and electrical connection of the device. The text information supplied is printed in 7 languages (English, Chinese, French, German, Italian, Russian, Spanish).

The CD contains a detailed manual (English, German) and configuration software with help text.

Note:

To use the CD, you need a PC with the Windows operating system (98, ME, NT, 2000 or XP). For connecting a PC (RS 232) to a DF6 frequency inverter (RS 422), you will need the DEX-CBL-2M0-PC connection cable.



Moeller HPL0211-2004/2005



Application

The DV6 is the most powerful vector control frequency inverter of its class, with more than 200 % starting torque and virtually full static torque without feedback (sensorless). It guarantees the highest levels of smooth operation and is particularly suited to highly-dynamic applications in the packaging, printing and textile industries, for machine tools, and in material handling with elevator systems and hoists.

The DV6 can be used as a stand-alone drive or incorporated in complex automation systems.

The assigned performance range for four-pole three-phase asynchronous motors ranges from 0.75 kW to 132 kW at 400 V.

Features

- Sensorless vector control (closed/open loop)
- Motor autotuning (online/offline)
- Built-in braking transistor (DV6-340-075 to DV6-340-11K)
- 32-bit processor
- Plug-in keypad (external installation possible) with four-character seven-segment display, six function keys and a setpoint value potentiometer
- RS 485 and RS 422 serial interface
- Nine digital inputs (24 V DC)
- Three analog inputs (0 to +10 V, ± 10 V, 4 to 20 mA)
- Thermistor input
- Five digital outputs (24 V DC)
- Two analog outputs (0/+10 V, 4 – 20 mA)
- Relay (changeover contact: 24 V DC/230 V AC)
- Bus interface (PROFIBUS DP) can be integrated.
- Global standards conforming to CE, UL, cUL, CSA and cTick

Function

Comprehensive protective functions guarantee safe operation and protect frequency inverters and motors:

- Overcurrent, earth fault
- Overload, electronic motor protection
- Overtemperature
- Overvoltage, undervoltage
- Phase failure
- Configurable delay with emergency-off and voltage failure

Three parameter sets with comprehensive functions:

- P/PI controller and PID closed-loop controller
- Automatic voltage regulation
- Motor synchronization and flying restart circuit
- Rapid stop function
- User macro memory
- Electronic motor potentiometer function
- 16 fixed frequencies (bit/binary)
- Min./max. frequency limitation

Documentation

Each DV6 frequency inverter is supplied with an instruction sheet (AWA) for mounting and connection, and a CD.

The AWA contains a short description with illustrations and information about correct handling, installation and electrical connection of the device. The text information supplied is printed in 7 languages (English, Chinese, French, German, Italian, Russian, Spanish).

The CD contains a detailed manual (English, German) and configuration software with help text.

Note:

To use the CD, you need a PC with the Windows operating system (98, ME, NT, 2000 or XP).

For connecting a PC (RS 232) to a DV6 frequency inverter (RS 422), you will need the DEX-CBL-2M0-PC connection cable.



	Motor			Frequency inverter					Power supply					
	Assigned motor rating	Rated operational current	Mains current Without mains choke or mains filter	Mains fuse ⁴⁾	Mains contactor	Mains choke ¹⁾	Radio interference suppression filter	Motor choke						
									P kW	I_e A	I_N A			
DF6 frequency inverters														
Three-phase power supply (400 V AC)														
DF6-340-11K	11	22	24	PKM0-25 ⁵⁾	DIL0M	DEX-LN3-025	DE6-LZ3-032-V4	DEX-LM3-035						
DF6-340-15K	15	29	32	PKZM4-40	DIL0M	DEX-LN3-040	DE6-LZ3-032-V4	DEX-LM3-035						
DF6-340-18K5	18.5	37	41	PKZM4-50	DIL1M	DEX-LN3-040	DE6-LZ3-064-V4	DEX-LM3-050						
DF6-340-22K	22	43	47	PKZM4-50	DIL1M	DEX-LN3-050	DE6-LZ3-064-V4	DEX-LM3-050						
DF6-340-30K	30	57	63	PKZM4-63	DIL2M	DEX-LN3-060	DE6-LZ3-064-V4	DEX-LM3-063						
DF6-340-37K	37	70	77	NZM...1-S80 ²⁾	DIL2M	DEX-LN3-080	DE6-LZ3-080-V4	DEX-LM3-080						
DF6-340-45K	45	85	94	NZM...1-S100 ²⁾	DIL3M80	DEX-LN3-100	DE6-LZ3-115-V4	DEX-LM3-100						
DF6-340-55K	55	105	116	NZM...1-S125 ²⁾	DIL4M115	DEX-LN3-120	DE6-LZ3-115-V4	DEX-LM3-150						
DF6-340-75K	75	135	149	NZM...1-S160 ²⁾	DIL4M115	DEX-LN3-160	DE6-LZ3-150-V4	DEX-LM3-150						
DF6-340-90K	90	160	176	NZM...2-S200 ²⁾	DILM185	DEX-LN3-160	DE6-LZ3-220-V4	DEX-LM3-180						
DF6-340-110K	110	195	215	NZM...3-ME220 ³⁾	DILM185	DEX-LN3-200	DE6-LZ3-220-V4	DEX-LM3-220						
DF6-340-132K	132	230	253	NZM...3-ME350 ³⁾	DILM225	DEX-LN3-250	DE6-LZ3-260-V4	DEX-LM3-260						

Notes

- ¹⁾ Mains chokes reduce the harmonic currents by up to 30 % and extend the frequency inverters' lifespan.
- ²⁾ Short-circuit protection for mounting in control panel (no overload release required).
- ³⁾ Applications without electronic overload release: set I_r = infinite.
- ⁴⁾ Switching capacity (kA) according to power supply rating.

Use NZM for mains protection → Main Catalogue 2004/2005, Industrial Switchgear, section 10
 Use PKZ for mains protection → Main Catalogue 2004/2005, Industrial Switchgear, section 8
 DIL mains contactors → Main Catalogue 2004/2005, Industrial Switchgear, section 5
 DEX-LN-... mains chokes → Page 18/75



Moeller HPL0211-2004/2005

	Motor			Frequency inverter					Power supply				
	Assigned motor rating	Rated operational current	Mains current Without mains choke or mains filter	Mains fuse ⁴⁾	Mains contactor	Mains choke ¹⁾	Radio interference suppression filter	Motor choke					
									P kW	I_e A	I_N A		
DV6 frequency inverters													
Three-phase power supply (400 V AC)													
DV6-340-075	0.75	2.5	2.8	PKM0-6.3 ²⁾	DIL00M	DEX-LN3-004	DE6-LZ3-013-V4	DEX-LM3-005					
DV6-340-1K5	1.5	3.8	4.2	PKM0-6,3 ²⁾	DIL00M	DEX-LN3-004	DE6-LZ3-013-V4	DEX-LM3-005					
DV6-340-2K2	2.2	5.3	5.8	PKM0-10 ²⁾	DIL00M	DEX-LN3-006	DE6-LZ3-013-V4	DEX-LM3-008					
DV6-340-4K0	4	8.6	9.5	PKM0-10 ²⁾	DIL00M	DEX-LN3-010	DE6-LZ3-013-V4	DEX-LM3-011					
DV6-340-5K5	5.5	12	13	PKM0-16 ²⁾	DIL00M	DEX-LN3-016	DE6-LZ3-013-V4	DEX-LM3-016					
DV6-340-7K5	7.5	16	18	PKM0-20 ²⁾	DIL00M	DEX-LN3-025	DE6-LZ3-032-V4	DEX-LM3-016					
DV6-340-11K	11	23	25	PKZM4-40	DIL0M	DEX-LN3-025	DE6-LZ3-032-V4	DEX-LM3-035					
DV6-340-15K	15	32	35	PKZM4-40	DIL0M	DEX-LN3-040	DE6-LZ3-064-V4	DEX-LM3-035					
DV6-340-18K5	18.5	38	42	PKZM4-50	DIL1M	DEX-LN3-040	DE6-LZ3-064-V4	DEX-LM3-035					
DV6-340-22K	22	48	53	PKZM4-58	DIL1M	DEX-LN3-050	DE6-LZ3-064-V4	DEX-LM3-050					
DV6-340-30K	30	58	63	NZM...1-S80 ²⁾	DIL2M	DEX-LN3-060	DE6-LZ3-080-V4	DEX-LM3-063					
DV6-340-37K	37	75	83	NZM...1-S100 ²⁾	DIL2M	DEX-LN3-080	DE6-LZ3-115-V4	DEX-LM3-080					
DV6-340-45K	45	90	99	NZM...1-S100 ²⁾	DIL3M80	DEX-LN3-100	DE6-LZ3-115-V4	DEX-LM3-100					
DV6-340-55K	55	110	121	NZM...1-S125 ²⁾	DIL4M115	DEX-LN3-120	DE6-LZ3-125-V4	DEX-LM3-150					
DV6-340-75K	75	149	164	NZM...2-S200 ²⁾⁵⁾	DIL4M115	DEX-LN3-160	DE6-LZ3-220-V4	DEX-LM3-150					
DV6-340-90K	90	176	194	NZM...2-S200 ²⁾	DILM185	DEX-LN3-200	DE6-LZ3-220-V4	DEX-LM3-180					
DV6-340-110K	110	217	239	NZM...3-ME350 ³⁾	DILM225	DEX-LN3-250	DE6-LZ3-260-V4	DEX-LM3-220					
DV6-340-132K	132	260	286	NZM...3-ME350 ³⁾	DILM250	DEX-LN3-300	DE6-LZ3-260-V4	DEX-LM3-260					

Notes

- ¹⁾ Mains chokes reduce the harmonic currents by up to 30 % and extend the frequency inverters' lifespan.
- ²⁾ Short-circuit protection for mounting in control panel (no overload release required).
- ³⁾ Applications without electronic overload release: set I_r = infinite.
- ⁴⁾ Switching capacity (kA) according to power supply rating.
- ⁵⁾ When using with DEX-LN3-160 mains choke, you can use NZM...2-S160.

Use NZM for mains protection → Main Catalogue 2004/2005, Industrial Switchgear, section 10
 Use PKZ for mains protection → Main Catalogue 2004/2005, Industrial Switchgear, section 8
 DIL mains contactors → Main Catalogue 2004/2005, Industrial Switchgear, section 5
 DEX-LN-... mains chokes → Page 18/75



DF6-340-... frequency inverters

Actuation

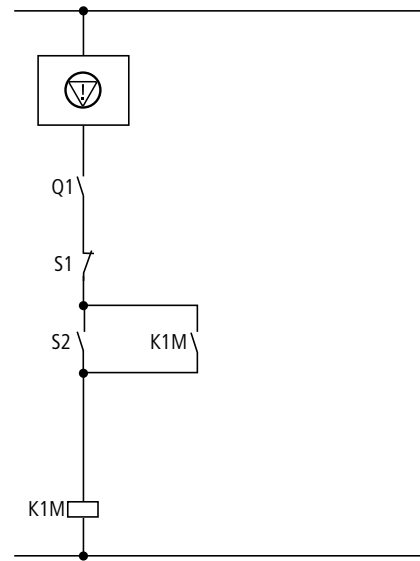

Example

Temperature regulation for ventilation system.
When the room temperature rises, the fan speed must increase.
The target temperature can be set with potentiometer R1 (e.g. 20 °C)

- Emergency-Stop circuit
- S1: OFF
- S2: ON
- K1M: Mains contactor
- Q1: Line protection
- PES: PE connection of cable screen
- Z1: Radio interference suppression filter

Wiring

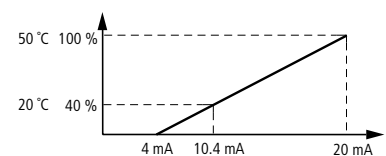
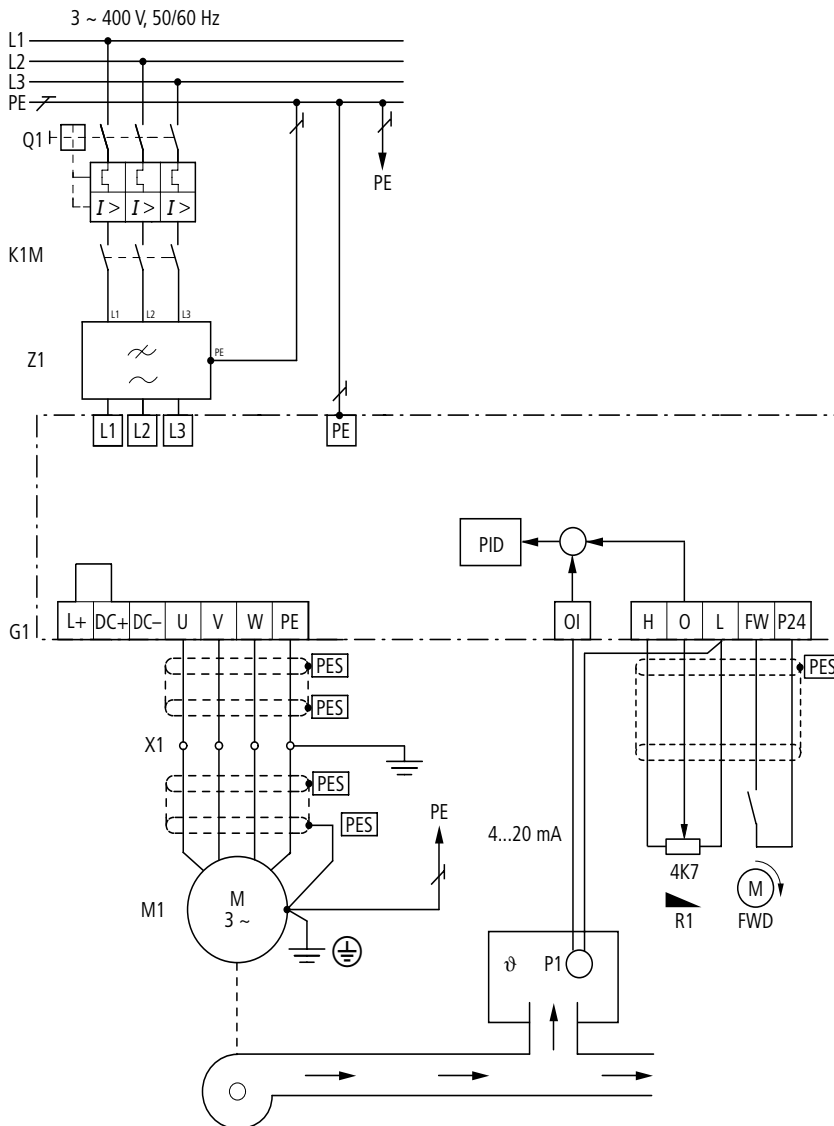

Moeller HPL0211-2004/2005

DV6-340-... vector frequency inverters with built-in encoder module (DE6-IOM-ENC) and external DE4-BR1-... braking resistor

Actuation

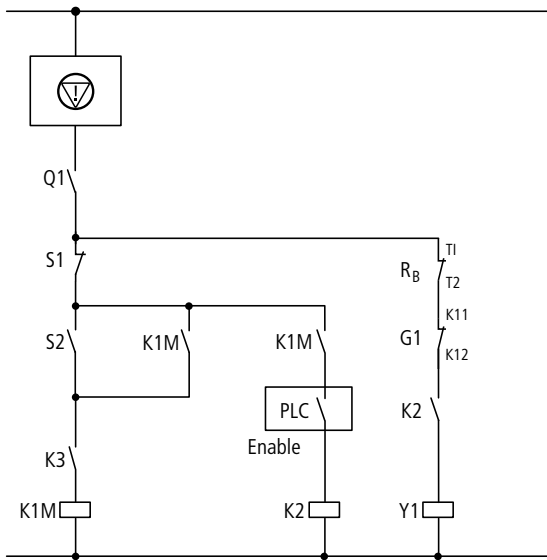

Example

Lifting apparatus with speed control; PLC monitors and controls Motor with thermistor (PTC resistor)

- Emergency-Stop circuit
- S1: OFF
- S2: ON
- Q1: Line protection
- K1M: Mains contactor
- K2: Control contactor enable
- R_B: Braking resistor
- B1: Encoder, 3 channels
- PES: PE connection of cable screen
- Y1: Holding brake

Wiring

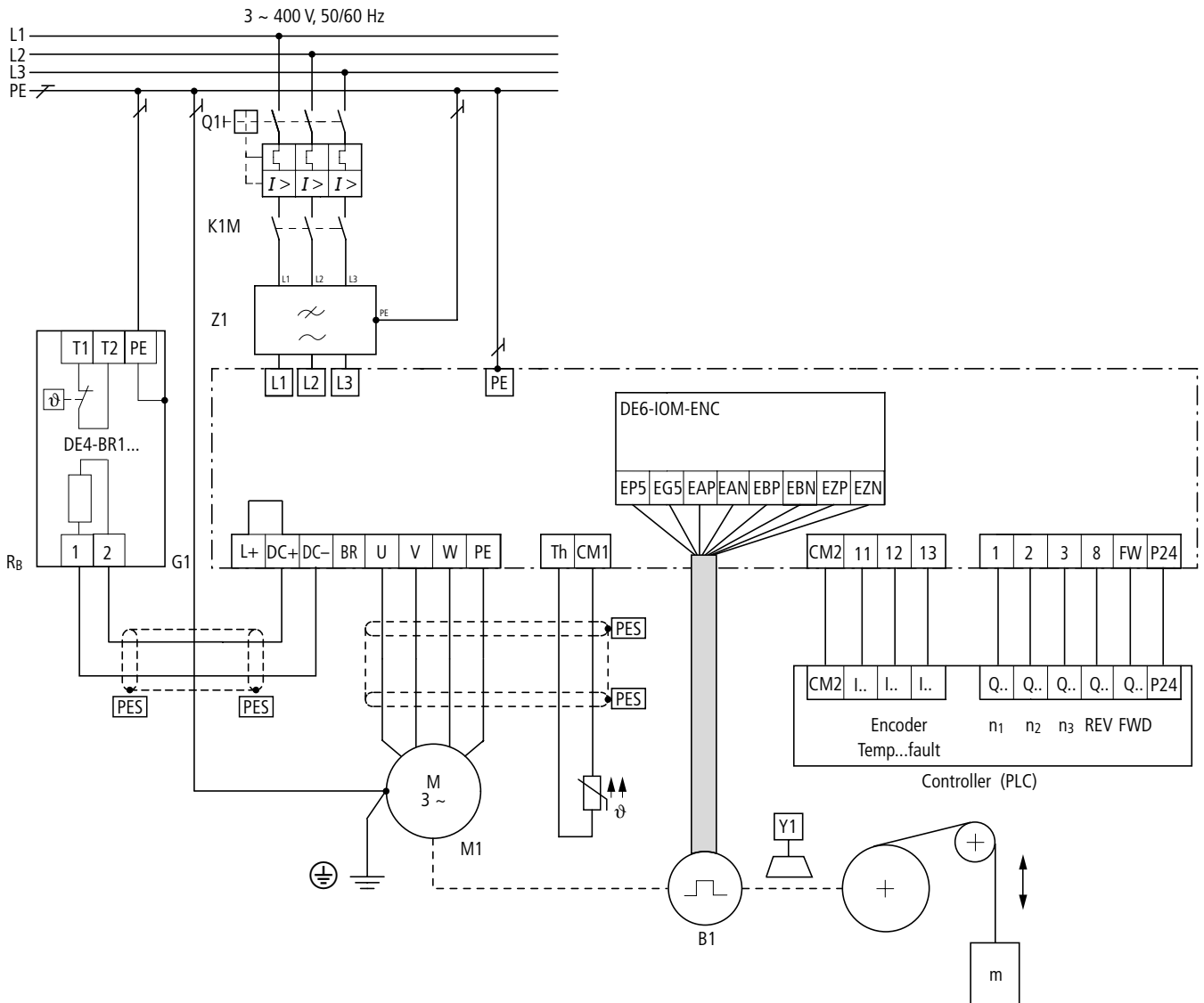

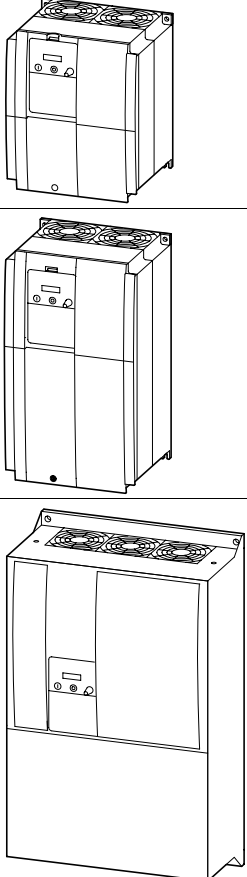
	Rated voltage U_e V	Max. rated operational current ¹⁾ I_e A	Rated power of motors At 400 V AC 3-phase P kW	Type Article no.	Price See Price List	Std. pack
Vector frequency inverters, 11 kW to 132 kW at 400 V						
	3 AC 342 – 528 V ± 0 %	22	11	DF6-340-11K 231384		1 off
		29	15	DF6-340-15K 231385		
		37	18.5	DF6-340-18K5 231386		
		43	22	DF6-340-22K 231387		
		57	30	DF6-340-30K 231388		
		70	37	DF6-340-37K 231389		
		85	45	DF6-340-45K 231390		
		105	55	DF6-340-55K 231391		
		135	75	DF6-340-75K 231392		
		160	90	DF6-340-90K 231393		
		195	110	DF6-340-110K 231394		
		230	132	DF6-340-132K 231395		

Notes

¹⁾ Rated operational current at an operating frequency of 5 kHz and an ambient temperature of +40 °C.

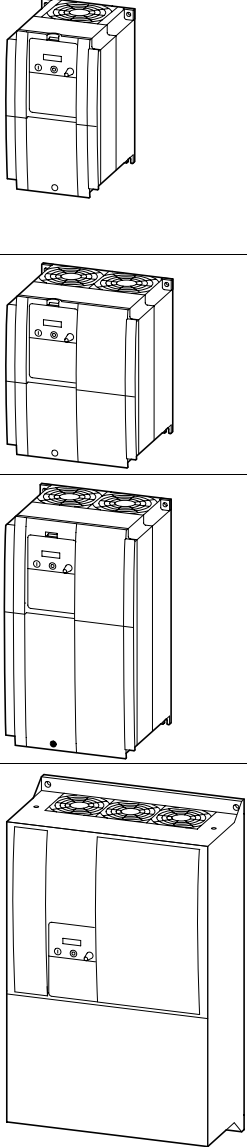

Moeller HPL0211-2004/2005

	Rated voltage	Max. rated operational current ¹⁾	Rated power of motors	Type Article no.	Price	Std. pack
	U_e V	I_e A	At 400 V 3-phase AC P kW		See Price List	
Vector frequency inverters, 0.75 kW to 132 kW at 400 V						
	3 AC 342 – 528 V ± 0 %	2.5	0.75	DV6-340-075 231396		1 off
		3.8	1.5	DV6-340-1K5 231397		
		5.3	2.2	DV6-340-2K2 231398		
		8.6	4	DV6-340-4K0 231399		
		12	5.5	DV6-340-5K5 231400		
		16	7.5	DV6-340-7K5 231401		
		23	11	DV6-340-11K 231402		
		32	15	DV6-340-15K 231403		
		38	18.5	DV6-340-18K5 231404		
		48	22	DV6-340-22K 231405		
		58	30	DV6-340-30K 231406		
		75	37	DV6-340-37K 231407		
		90	45	DV6-340-45K 231408		
		110	55	DV6-340-55K 231409		
		149	75	DV6-340-75K 231410		
		176	90	DV6-340-90K 231411		
217	110	DV6-340-110K 231412				
260	132	DV6-340-132K 231413				

Notes

¹⁾ Rated operational current at an operating frequency of 5 kHz and an ambient temperature of +40 °C.

DF5, DF6 frequency inverters
DV5, DV6 vector frequency inverters



Moeller HPL0211-2004/2005

		DF6-340-11K	DF6-340-15K	DF6-340-18K5
General				
Standards		EN 50178, IEC 61800-3, EN 61800-3 incl. A11		
Ambient temperature				
Operating temperature	°C	-10 to +40 at rated current I_e without derating, up to 50 at a reduced pulse frequency of 2 kHz and output current reduced to 80 % I_e		
Storage, transport	°C	-25 – +70		
Mechanical shock resistance		Vibration and impact, max. 5.9 m/s ² (0.6 g) at 10 to 55 Hz		
Pollution degree		VDE 0110 Part 2, pollution degree 2		
Climatic proofing		Class 3K3 according to EN 50178 (non-condensing, average relative humidity 20 to 90 %)		
Altitude	m	0 – 1000 above sea level		
Mounting position		Vertically suspended		
Free surrounding areas		100 mm above and below device		
Emitted interference		IEC/EN 61800-3 (EN 55011 group 1 class B)		
Noise immunity		IEC/EN 61800-3, industrial environment		
Insulation resistance		Overvoltage category III according to VDE 0110		
Leakage current to PE	mA	> 3.5 (according to EN 50178)		
Degree of protection		IP 20		
Contact protection		Finger and back-of-hand proof (BGV A2)		
Protective isolation from switching circuitry		Safe isolation from the mains. Double basic isolation (according to EN 50178)		
Protective measures		Overcurrent, earth fault, overvoltage, undervoltage, overload, overtemperature, electronic overload protection: I^2t monitoring and PTC input (thermistor or thermostat)		
Heat dissipation at rated operational current I_e	W	600	800	975
Dimensions (w × h × d)	mm	216 × 266 × 190.5	216 × 266 × 190.5	256 × 396 × 210.5
Weight	kg	5	5	12
Power section				
Rated operational voltage	V AC	400	400	400
Rated voltage	U_e V	3 AC 342 – 528 V ± 0 %	3 AC 342 – 528 V ± 0 %	3 AC 342 – 528 V ± 0 %
Supply frequency	Hz	50/60 (47 -0 % to 63 +0 %)	50/60 (47 -0 % to 63 +0 %)	50/60 (47 -0 % to 63 +0 %)
Mains current				
$U_i = 400$ V AC three-phase	I A	24	32	41
Alternative DC supply	U_{DC} V DC	420 – 760	420 – 760	420 – 760
Modulation method		Sine-wave pulse-width modulation (PWM), U/f characteristic control		
Switching frequency		5 kHz, can be selected between 0.5 and 12 kHz		
Output voltage	V	3 AC U_e	3 AC U_e	3 AC U_e
Output frequency	Hz	0.5 – 50, max. 400	0.5 – 50, max. 400	0.5 – 50, max. 400
Frequency resolution	Hz	0.1, with digital setpoint values/maximum frequency/1000 with analog setpoint values		
Frequency error threshold at 20 °C ± 10 K		±0.01 % of maximum frequency for digital reference values, ±0.2 % of maximum frequency for analog reference values		
Max. rated operational current	I_e A	22	29	37
Permissible overcurrent		120 % for 60 s/150 % for 0.5 s, every 600 s		
Torque during start		Square-law linear load characteristic (base frequency 30 – 400 Hz)		
Apparent power at 400 V	kVA	15.2	20	25.6
Apparent power at 480 V	kVA	18.2	24.1	30
Standard operation at 120 % overload Assigned motor rating (4-pole ASM)				
400 V	kW	11	15	18.5
460 V	HP	15	20	25
Brake transistor				
Switching threshold	U_{DC} V DC	740	740	–
Resistance R_B at 100 % DF	R Ω	150	150	–
Lowest impedance	R_B Ω	50	50	–
Max. duty factor (DF) at lowest impedance R_B	% DF	10	10	–

Notes

If the frequency inverter is to be installed in an enclosure, control panel or similar housing, the ambient temperature T_a is taken to be the temperature inside this enclosure or control panel. All rating data of the power section is based on a switching frequency of 5 kHz (default setting) and an ambient temperature of +40 °C, for operation of a four-pole three-phase asynchronous motor.

Moeller HPL0211-2004/2005

		DF6-340-22K	DF6-340-30K	DF6-340-37K
General				
Standards		EN 50178, IEC 61800-3, EN 61800-3 incl. A11		
Ambient temperature				
Operating temperature	°C	-10 to +40 at rated current I_e without derating, up to 50 at a reduced pulse frequency of 2 kHz and output current reduced to 80 % I_e		
Storage, transport	°C	-25 – +70		
Mechanical shock resistance		Vibration and impact, max. 5.9 m/s ² (0.6 g) at 10 to 55 Hz		
Pollution degree		VDE 0110 Part 2, pollution degree 2		
Climatic proofing		Class 3K3 according to EN 50178 (non-condensing, average relative humidity 20 to 90 %)		
Altitude	m	0 – 1000 above sea level		
Mounting position		Vertically suspended		
Free surrounding areas		100 mm above and below device		
Emitted interference		IEC/EN 61800-3 (EN 55011 group 1 class B)		
Noise immunity		IEC/EN 61800-3, industrial environment		
Insulation resistance		Overvoltage category III according to VDE 0110		
Leakage current to PE	mA	> 3.5 (according to EN 50178)		
Degree of protection		IP 20		
Contact protection		Finger and back-of-hand proof (BGV A2)		
Protective isolation from switching circuitry		Safe isolation from the mains. Double basic isolation (according to EN 50178)		
Protective measures		Overcurrent, earth fault, overvoltage, undervoltage, overload, overtemperature, electronic overload protection: I^2t monitoring and PTC input (thermistor or thermostat)		
Heat dissipation at rated operational current I_e	W	1150	1550	1900
Dimensions (w × h × d)	mm	256 × 396 × 210.5	256 × 396 × 210.5	316 × 546 × 215.5
Weight	kg	12	12	20
Power section				
Rated operational voltage	V AC	400	400	400
Rated voltage	U_e V	3 AC 342 – 528 V ± 0 %	3 AC 342 – 528 V ± 0 %	3 AC 342 – 528 V ± 0 %
Supply frequency	Hz	50/60 (47 -0 % to 63 +0 %)	50/60 (47 -0 % to 63 +0 %)	50/60 (47 -0 % to 63 +0 %)
Mains current				
$U_i = 400$ V AC three-phase	I A	47	63	77
Alternative DC supply	U_{DC} V DC	420 – 760	420 – 760	420 – 760
Modulation method		Sine-wave pulse-width modulation (PWM), U/f characteristic control		
Switching frequency		5 kHz, can be selected between 0.5 and 12 kHz		
Output voltage	V	3 AC U_e	3 AC U_e	3 AC U_e
Output frequency	Hz	0.5 – 50, max. 400	0.5 – 50, max. 400	0.5 – 50, max. 400
Frequency resolution	Hz	0.1, with digital setpoint values/maximum frequency/1000 with analog setpoint values		
Frequency error threshold at 20 °C ± 10 K		±0.01 % of maximum frequency for digital reference values, ±0.2 % of maximum frequency for analog reference values		
Max. rated operational current	I_e A	43	57	70
Permissible overcurrent		120 % for 60 s/150 % for 0.5 s, every 600 s		
Torque during start		Square-law linear load characteristic (base frequency 30 – 400 Hz)		
Apparent power at 400 V	kVA	29.7	39.4	48.4
Apparent power at 480 V	kVA	35.7	47.3	58.1
Standard operation at 120 % overload Assigned motor rating (4-pole ASM)				
400 V	kW	22	30	37
460 V	HP	30	40	50
Brake transistor				
Switching threshold	U_{DC} V DC	–	–	–
Resistance R_B at 100 % DF	R Ω	–	–	–
Lowest impedance	R_B Ω	–	–	–
Max. duty factor (DF) at lowest impedance R_B	% DF	–	–	–



Moeller HPL0211-2004/2005

		DF6-340-11K	DF6-340-15K	DF6-340-18K5
Control circuit				
Thermistor input		1 × PTC thermistor, thermostat		
Relays		1 × changeover contact, 230 V AC/0.2 A inductive load/2.5 A resistive load or 24 V DC/0.7 A inductive load/3 A resistive load; 2 × make contact, 230 V AC/1 A inductive load/5 A resistive load or 24 V DC/1 A inductive load/5 A resistive load		
Serial interface		RS 422, RS 485	RS 422, RS 485	RS 422, RS 485
Control voltage				
Output setpoint voltage	V	+10 DC, 20 mA	+10 DC, 20 mA	+10 DC, 20 mA
Output control voltage	V	+24 DC, 100 mA	+24 DC, 100 mA	+24 DC, 100 mA
Parameterization		2 × parameter sets (online/offline parameterization), parameter protection (programmable)		
Inputs				
Digital (configurable)		6 × +24 V DC (5 × configurable, 1 × FWD)		
Analog, 8-bit resolution	Number	2 × 0 – +10 V DC (input impedance 10 kΩ, 4 – 20 mA (load impedance 100 Ω))		
Outputs				
Analog (configurable), 8-bit resolution		1 × 0 – +10 V DC, 2 mA	1 × 0 – +10 V DC, 2 mA	1 × 0 – +10 V DC, 2 mA
PWM (configurable)		4 – 20 mA (max. load impedance 250 Ω)		
		0 – 10 V, max. 1.2 mA	0 – 10 V, max. 1.2 mA	0 – 10 V, max. 1.2 mA
Terminal capacities				
Power cables	mm ²	6	10	16
	AWG	8	6	6
Relay connection	mm ²	0.14 – 1.5	0.14 – 1.5	0.14 – 1.5
	AWG	16 – 6	16 – 6	16 – 6
Control circuit	mm ²	0.14 – 1.5	0.14 – 1.5	0.14 – 1.5
	AWG	16 – 6	16 – 6	16 – 6

Notes
If the frequency inverter is to be installed in an enclosure, control panel or similar housing, the ambient temperature T_a is taken to be the temperature inside this enclosure or control panel. All rating data of the power section is based on a switching frequency of 5 kHz (default setting) and an ambient temperature of +40 °C, for operation of a four-pole three-phase asynchronous motor.

Moeller HPL0211-2004/2005

		DF6-340-22K	DF6-340-30K	DF6-340-37K
Control circuit				
1 × PTC thermistor, thermostat				
1 × changeover contact, 230 V AC/0.2 A inductive load/2.5 A resistive load or 24 V DC/0.7 A inductive load/3 A resistive load; 2 × make contact, 230 V AC/1 A inductive load/5 A resistive load or 24 V DC/1 A inductive load/5 A resistive load				
Serial interface		RS 422, RS 485	RS 422, RS 485	RS 422, RS 485
Control voltage				
Output setpoint voltage		+10 DC, 20 mA	+10 DC, 20 mA	+10 DC, 20 mA
Output control voltage		+24 DC, 100 mA	+24 DC, 100 mA	+24 DC, 100 mA
2 × parameter sets (online/offline parameterization), parameter protection (programmable)				
Inputs				
6 × +24 V DC (5 × configurable, 1 × FWD)				
2 × 0 – +10 V DC (input impedance 10 kΩ, 4 – 20 mA (load impedance 100 Ω))				
Outputs				
Analog (configurable), 8-bit resolution		1 × 0 – +10 V DC, 2 mA	1 × 0 – +10 V DC, 2 mA	1 × 0 – +10 V DC, 2 mA
4 – 20 mA (max. load impedance 250 Ω)				
PWM (configurable)		0 – 10 V, max. 1.2 mA	0 – 10 V, max. 1.2 mA	0 – 10 V, max. 1.2 mA
Terminal capacities				
Power cables	mm ²	25	25	35
	AWG	4	3	1
Relay connection	mm ²	0.14 – 1.5	0.14 – 1.5	0.14 – 1.5
	AWG	16 – 6	16 – 6	16 – 6
Control circuit	mm ²	0.14 – 1.5	0.14 – 1.5	0.14 – 1.5
	AWG	16 – 6	16 – 6	16 – 6

DF5, DF6 frequency inverters
DV5, DV6 vector frequency inverters

DF5, DF6 frequency inverters
DV5, DV6 vector frequency inverters



Moeller HPL0211-2004/2005

		DF6-340-45K	DF6-340-55K	DF6-340-75K
General				
Standards		EN 50178, IEC 61800-3, EN 61800-3 incl. A11		
Ambient temperature				
Operating temperature	°C	-10 to +40 at rated current I_e without derating, up to 50 at a reduced pulse frequency of 2 kHz and output current reduced to 80 % I_e		
Storage, transport	°C	-25 – +70		
Mechanical shock resistance		Vibration and impact, max. 2.94 m/s ² (0.3 g) at 10 to 55 Hz		
Pollution degree		VDE 0110 Part 2, pollution degree 2		
Climatic proofing		Class 3K3 according to EN 50178 (non-condensing, average relative humidity 20 to 90 %)		
Altitude	m	0 – 1000 above sea level		
Mounting position		Vertically suspended		
Free surrounding areas		100 mm above and below device		
Emitted interference		IEC/EN 61800-3 (EN 55011 group 1 class B)		
Noise immunity		IEC/EN 61800-3, industrial environment		
Insulation resistance		Overvoltage category III according to VDE 0110		
Leakage current to PE	mA	> 3.5 (according to EN 50178)		
Degree of protection		IP 20		
Contact protection		Finger and back-of-hand proof (BGV A2)		
Protective isolation from switching circuitry		Safe isolation from the mains. Double basic isolation (according to EN 50178)		
Protective measures		Overcurrent, earth fault, overvoltage, undervoltage, overload, overtemperature, electronic overload protection: I^2t monitoring and PTC input (thermistor or thermostat)		
Heat dissipation at rated operational current I_e	W	2300	2800	3750
Dimensions (w × h × d)	mm	396 × 556 × 270.5	396 × 556 × 270.5	396 × 556 × 270.5
Weight	kg	30	30	30
Power section				
Rated operational voltage	V AC	400	400	400
Rated voltage	U_e V	3 AC 342 – 528 V ± 0 %	3 AC 342 – 528 V ± 0 %	3 AC 342 – 528 V ± 0 %
Supply frequency	Hz	50/60 (47 -0 % to 63 +0 %)	50/60 (47 -0 % to 63 +0 %)	50/60 (47 -0 % to 63 +0 %)
Mains current				
$U_i = 400$ V AC three-phase	I A	94	116	149
Alternative DC supply	U_{DC} V DC	420 – 760	420 – 760	420 – 760
Modulation method		Sine-wave pulse-width modulation (PWM), U/f characteristic control		
Switching frequency		5 kHz, can be selected between 0.5 and 12 kHz		
Output voltage	V	3 AC U_e	3 AC U_e	3 AC U_e
Output frequency	Hz	0.5 – 50, max. 400	0.5 – 50, max. 400	0.5 – 50, max. 400
Frequency resolution	Hz	0.1, with digital setpoint values/maximum frequency/1000 with analog setpoint values		
Frequency error threshold at 20 °C ± 10 K		±0.01 % of maximum frequency for digital reference values, ±0.2 % of maximum frequency for analog reference values		
Max. rated operational current	I_e A	85	105	135
Permissible overcurrent		120 % for 60 s/150 % for 0.5 s, every 600 s		
Torque during start		Square-law linear load characteristic (base frequency 30 – 400 Hz)		
Apparent power at 400 V	kVA	58.8	72.7	93.5
Apparent power at 480 V	kVA	70.1	87.1	112
Standard operation at 120 % overload Assigned motor rating (4-pole ASM)				
400 V	kW	45	55	75
460 V	HP	60	75	100

Notes

If the frequency inverter is to be installed in an enclosure, control panel or similar housing, the ambient temperature T_a is taken to be the temperature inside this enclosure or control panel. All rating data of the power section is based on a switching frequency of 5 kHz (default setting) and an ambient temperature of +40 °C, for operation of a four-pole three-phase asynchronous motor.

Moeller HPL0211-2004/2005

		DF6-340-90K	DF6-340-110K	DF6-340-132K
General				
Standards		EN 50178, IEC 61800-3, EN 61800-3 incl. A11		
Ambient temperature				
Operating temperature	°C	-10 to +40 at rated current I_e without derating, up to 50 at a reduced pulse frequency of 2 kHz and output current reduced to 80 % I_e		
Storage, transport	°C	-25 – +70		
Mechanical shock resistance		Vibration and impact, max. 2.94 m/s ² (0.3 g) at 10 to 55 Hz		
Pollution degree		VDE 0110 Part 2, pollution degree 2		
Climatic proofing		Class 3K3 according to EN 50178 (non-condensing, average relative humidity 20 to 90 %)		
Altitude	m	0 – 1000 above sea level		
Mounting position		Vertically suspended		
Free surrounding areas		100 mm above and below device		
Emitted interference		IEC/EN 61800-3 (EN 55011 group 1 class B)		
Noise immunity		IEC/EN 61800-3, industrial environment		
Insulation resistance		Overvoltage category III according to VDE 0110		
Leakage current to PE	mA	> 3.5 (according to EN 50178)		
Degree of protection		IP 20		
Contact protection		Finger and back-of-hand proof (BGV A2)		
Protective isolation from switching circuitry		Safe isolation from the mains. Double basic isolation (according to EN 50178)		
Protective measures		Overcurrent, earth fault, overvoltage, undervoltage, overload, overtemperature, electronic overload protection: I^2t monitoring and PTC input (thermistor or thermostat)		
Heat dissipation at rated operational current I_e	W	4500	5500	6500
Dimensions (w × h × d)	mm	396 × 706 × 290.5	396 × 706 × 290.5	486 × 746 × 282
Weight	kg	60	60	80
Power section				
Rated operational voltage	V AC	400	400	400
Rated voltage	U_e V	3 AC 342 – 528 V ± 0 %	3 AC 342 – 528 V ± 0 %	3 AC 342 – 528 V ± 0 %
Supply frequency	Hz	50/60 (47 -0 % to 63 +0 %)	50/60 (47 -0 % to 63 +0 %)	50/60 (47 -0 % to 63 +0 %)
Mains current				
$U_i = 400$ V AC three-phase	I A	176	215	253
Alternative DC supply	U_{DC} V DC	420 – 760	420 – 760	420 – 760
Modulation method		Sine-wave pulse-width modulation (PWM), U/f characteristic control		
Switching frequency		5 kHz, can be selected between 0.5 and 12 kHz		
Output voltage	V	3 AC U_e	3 AC U_e	3 AC U_e
Output frequency	Hz	0.5 – 50, max. 400	0.5 – 50, max. 360	0.5 – 50, max. 360
Frequency resolution	Hz	0.1, with digital setpoint values/maximum frequency/1000 with analog setpoint values		
Frequency error threshold at 20 °C ± 10 K		±0.01 % of maximum frequency for digital reference values, ±0.2 % of maximum frequency for analog reference values		
Max. rated operational current	I_e A	160	195	230
Permissible overcurrent		120 % for 60 s/150 % for 0.5 s, every 600 s		
Torque during start		Square-law linear load characteristic (base frequency 30 – 400 Hz)		
Apparent power at 400 V	kVA	111	135	159
Apparent power at 480 V	kVA	133	162	191
Standard operation at 120 % overload Assigned motor rating (4-pole ASM)				
400 V	kW	90	110	132
460 V	HP	125	150	175



Moeller HPL0211-2004/2005

		DF6-340-45K	DF6-340-55K	DF6-340-75K
Control circuit				
Thermistor input		1 × PTC thermistor, thermostat		
Relays		1 × changeover contact, 230 V AC/0.2 A inductive load/2.5 A resistive load or 24 V DC/0.7 A inductive load/3 A resistive load; 2 × make contact, 230 V AC/1 A inductive load/5 A resistive load or 24 V DC/1 A inductive load/5 A resistive load		
Serial interface		RS 422, RS 485	RS 422, RS 485	RS 422, RS 485
Control voltage				
Output setpoint voltage	V	+10 DC, 20 mA	+10 DC, 20 mA	+10 DC, 20 mA
Output control voltage	V	+24 DC, 100 mA	+24 DC, 100 mA	+24 DC, 100 mA
Parameterization		2 × parameter sets (online/offline parameterization), parameter protection (programmable)		
Inputs				
Digital (configurable)		6 × +24 V DC (5 × configurable, 1 × FWD)		
Analog, 8-bit resolution	Number	2 × 0 – +10 V DC (input impedance 10 kΩ, 4 – 20 mA (load impedance 100 Ω))		
Outputs				
Analog (configurable), 8-bit resolution		1 × 0 – +10 V DC, 2 mA	1 × 0 – +10 V DC, 2 mA	1 × 0 – +10 V DC, 2 mA
PWM (configurable)		4 – 20 mA (max. load impedance 250 Ω)	0 – 10 V, max. 1.2 mA	0 – 10 V, max. 1.2 mA
Terminal capacities				
Power cables	mm ²	35	50	2 × 35
	AWG	1	1/0	2 × 1
Relay connection	mm ²	0.14 – 1.5	0.14 – 1.5	0.14 – 1.5
	AWG	16 – 6	16 – 6	16 – 6
Control circuit	mm ²	0.14 – 1.5	0.14 – 1.5	0.14 – 1.5
	AWG	16 – 6	16 – 6	16 – 6

Notes

If the frequency inverter is to be installed in an enclosure, control panel or similar housing, the ambient temperature T_a is taken to be the temperature inside this enclosure or control panel. All rating data of the power section is based on a switching frequency of 5 kHz (default setting) and an ambient temperature of +40 °C, for operation of a four-pole three-phase asynchronous motor.

Moeller HPL0211-2004/2005

		DF6-340-90K	DF6-340-110K	DF6-340-132K
Control circuit				
1 × PTC thermistor, thermostat				
1 × changeover contact, 230 V AC/0.2 A inductive load/2.5 A resistive load or 24 V DC/0.7 A inductive load/3 A resistive load; 2 × make contact, 230 V AC/1 A inductive load/5 A resistive load or 24 V DC/1 A inductive load/5 A resistive load				
Serial interface		RS 422, RS 485	RS 422, RS 485	RS 422, RS 485
Control voltage				
Output setpoint voltage		+10 DC, 20 mA	+10 DC, 20 mA	+10 DC, 20 mA
Output control voltage		+24 DC, 100 mA	+24 DC, 100 mA	+24 DC, 100 mA
2 × parameter sets (online/offline parameterization), parameter protection (programmable)				
Inputs				
6 × +24 V DC (5 × configurable, 1 × FWD)				
2 × 0 – +10 V DC (input impedance 10 kΩ, 4 – 20 mA (load impedance 100 Ω))				
Outputs				
Analog (configurable), 8-bit resolution		1 × 0 – +10 V DC, 2 mA	1 × 0 – +10 V DC, 2 mA	1 × 0 – +10 V DC, 2 mA
PWM (configurable)		4 – 20 mA (max. load impedance 250 Ω)	0 – 10 V, max. 1.2 mA	0 – 10 V, max. 1.2 mA
Terminal capacities				
Power cables		2 × 35	2 × 50	2 × 70
		2 × 1	2 × 1/0	2 × 1/0
Relay connection		0.14 – 1.5	0.14 – 1.5	0.14 – 1.5
		16 – 6	16 – 6	16 – 6
Control circuit		0.14 – 1.5	0.14 – 1.5	0.14 – 1.5
		16 – 6	16 – 6	16 – 6



Moeller HPL0211-2004/2005

		DV6-340-075	DV6-340-1K5	DV6-340-2K2
General				
Standards		EN 50178, IEC 61800-3, EN 61800-3 incl. A11		
Ambient temperature				
Operating temperature	°C	-10 to +40 at rated current I_e without derating, up to 50 at a reduced pulse frequency of 2 kHz and output current reduced to 80 % I_e		
Storage, transport	°C	-25 – +70		
Mechanical shock resistance		Vibration and impact, max. 5.9 m/s ² (0.6 g) at 10 to 55 Hz		
Pollution degree		VDE 0110 Part 2, pollution degree 2		
Climatic proofing		Class 3K3 according to EN 50178 (non-condensing, average relative humidity 20 to 90 %)		
Altitude	m	0 – 1000 above sea level		
Mounting position		Vertically suspended		
Free surrounding areas		100 mm above and below, 50 mm on each side		
Emitted interference		IEC/EN 61800-3 (EN 55011 group 1 class B)		
Noise immunity		IEC/EN 61800-3, industrial environment		
Insulation resistance		Overvoltage category III according to VDE 0110		
Leakage current to PE	mA	> 3.5 (according to EN 50178)		
Degree of protection		IP 20 (NEMA 1)		
Contact protection		Finger and back-of-hand proof (BGV A2)		
Protective isolation from switching circuitry		Safe isolation from the mains. Double basic isolation (according to EN 50178)		
Protective measures		Overcurrent, earth fault, overvoltage, undervoltage, overload, overtemperature, electronic overload protection: I^2t monitoring and PTC input (thermistor or thermostat)		
Heat dissipation at rated operational current I_e	W	88	125	160
Dimensions (w × h × d)	mm	159 × 260.5 × 152	159 × 260.5 × 152	159 × 260.5 × 152
Weight	kg	3.5	3.5	3.5
Power section				
Rated operational voltage	V AC	400	400	400
Rated voltage	U_e V	3 AC 342 – 528 V ± 0 %	3 AC 342 – 528 V ± 0 %	3 AC 342 – 528 V ± 0 %
Supply frequency	Hz	50/60 (47 -0 % to 63 +0 %)		
Mains current				
$U_i = 400$ V AC three-phase	I A	2.8	4.2	5.8
Alternative DC supply	U_{DC} V DC	420 – 760	420 – 760	420 – 760
Modulation method				
Sensorless vector control, pulse width modulation (PWM)				
Switching frequency				
5 kHz, adjustable from 0.5 to 15 kHz				
Output voltage	V	3 AC U_e	3 AC U_e	3 AC U_e
Output frequency	Hz	0.5 – 50, max. 400	0.5 – 50, max. 400	0.5 – 50, max. 400
Frequency resolution	Hz	0.1, with digital setpoint values/maximum frequency/1000 with analog setpoint values		
Frequency error threshold at 20 °C ± 10 K		±0.01 % of maximum frequency for digital reference values, ±0.2 % of maximum frequency for analog reference values		
Max. rated operational current	I_e A	2.5	3.8	5.3
Permissible overcurrent		150 % for 60 s/200 % for 0.5 s, every 600 s		
Torque during start				
200 % at 0.5 Hz (sensorless vector control mode)				
Apparent power at 400 V	kVA	1.7	2.6	3.6
Apparent power at 480 V	kVA	2	3.1	4.4
Standard operation at 150 % overload Assigned motor rating (4-pole ASM)				
400 V	kW	0.75	1.5	2.2
460 V	HP	1	2	3
Brake transistor				
Switching threshold	U_{DC} V DC	740	740	740
Resistance R_B at 100 % DF	R Ω	300	300	300
Lowest impedance	R_B Ω	100	100	100
Max. duty factor (DF) at lowest impedance R_B	% DF	10	10	10
Outputs				
Digital		5 × 24 V DC transistor (open-collector, max. 50 mA per output, configurable)		
Analog (configurable), 8-bit resolution		3 × 0 – +10 V DC (max. 2 mA), 4 – 20 mA (max. load impedance 250Ω)		
PWM (configurable)		1 × 0 – 10 V, max. 1.2 mA		

Notes

If the frequency inverter is to be installed in an enclosure, control panel or similar housing, the ambient temperature T_a is taken to be the temperature inside this enclosure or control panel. All rating data of the power section is based on a switching frequency of 5 kHz (default setting) and an ambient temperature of +40 °C, for operation of a four-pole three-phase asynchronous motor.

Moeller HPL0211-2004/2005

		DV6-340-4K0	DV6-340-5K5	DV6-340-7K5	DV6-340-11K	DV6-340-15K	DV6-340-18K5
General							
Standards							
EN 50178, IEC 61800-3, EN 61800-3 incl. A11							
Ambient temperature							
-10 to +40 at rated current I_e without derating, up to 50 at a reduced pulse frequency of 2 kHz and output current reduced to 80 % I_e							
-25 – +70							
Mechanical shock resistance							
Vibration and impact, max. 5.9 m/s ² (0.6 g) at 10 to 55 Hz							
Pollution degree							
VDE 0110 Part 2, pollution degree 2							
Climatic proofing							
Class 3K3 according to EN 50178 (non-condensing, average relative humidity 20 to 90 %)							
Altitude							
0 – 1000 above sea level							
Mounting position							
Vertically suspended							
Free surrounding areas							
100 mm above and below, 50 mm on each side							
Emitted interference							
IEC/EN 61800-3 (EN 55011 group 1 class B)							
Noise immunity							
IEC/EN 61800-3, industrial environment							
Insulation resistance							
Overvoltage category III according to VDE 0110							
Leakage current to PE							
> 3.5 (according to EN 50178)							
Degree of protection							
IP 20 (NEMA 1)							
Contact protection							
Finger and back-of-hand proof (BGV A2)							
Protective isolation from the mains. Double basic isolation (according to EN 50178)							
Overcurrent, earth fault, overvoltage, undervoltage, overload, overtemperature, electronic overload protection: I^2t monitoring and PTC input (thermistor or thermostat)							
Heat dissipation at rated operational current I_e		235	325	425	600	800	975
Dimensions (w × h × d)		159 × 260.5 × 152	159 × 260.5 × 152	216 × 266 × 182	216 × 266 × 182	256 × 396 × 210	256 × 396 × 210
Weight		3.5	3.5	5	5	12	12
Power section							
Rated operational voltage		400	400	400	400	400	400
Rated voltage		3 AC 342 – 528 V ± 0 %	3 AC 342 – 528 V ± 0 %	3 AC 342 – 528 V ± 0 %	3 AC 342 – 528 V ± 0 %	3 AC 342 – 528 V ± 0 %	3 AC 342 – 528 V ± 0 %
Supply frequency		50/60 (47 -0 % to 63 +0 %)					
Mains current							
$U_i = 400$ V AC three-phase		9.5	13	18	25	35	42
Alternative DC supply		420 – 760	420 – 760	420 – 760	420 – 760	420 – 760	420 – 760
Modulation method							
Sensorless vector control, pulse width modulation (PWM)							
Switching frequency							
5 kHz, adjustable from 0.5 to 15 kHz							
Output voltage		3 AC U_e	3 AC U_e	3 AC U_e	3 AC U_e	3 AC U_e	3 AC U_e
Output frequency		0.5 – 50, max. 400	0.5 – 50, max. 400	0.5 – 50, max. 400	0.5 – 50, max. 400	0.5 – 50, max. 400	0.5 – 50, max. 400
Frequency resolution		0.1, with digital setpoint values/maximum frequency/1000 with analog setpoint values					
Frequency error threshold at 20 °C ± 10 K		±0.01 % of maximum frequency for digital reference values, ±0.2 % of maximum frequency for analog reference values					
Max. rated operational current		8.6	12	16	23	32	38
Permissible overcurrent		150 % for 60 s/200 % for 0.5 s, every 600 s					
Torque during start							
200 % at 0.5 Hz (sensorless vector control mode)							
Apparent power at 400 V		5.9	8.3	11	15.9	22.1	26.3
Apparent power at 480 V		7.1	9.9	13.3	19.1	26.6	31.5
Standard operation at 150 % overload Assigned motor rating (4-pole ASM)							
400 V		4	5.5	7.5	11	15	18.5
460 V		5	7.5	10	15	20	25
Brake transistor							
Switching threshold		740	740	740	740	–	–
Resistance R_B at 100 % DF		200	200	150	150	–	–
Lowest impedance		70	70	50	50	–	–
Max. duty factor (DF) at lowest impedance R_B		10	10	10	10	–	–
Outputs							
Digital		5 × 24 V DC transistor (open-collector, max. 50 mA per output, configurable)					
Analog (configurable), 8-bit resolution		3 × 0 – +10 V DC (max. 2 mA), 4 – 20 mA (max. load impedance 250Ω)					
PWM (configurable)		1 × 0 – 10 V, max. 1.2 mA					

DF5, DF6 frequency inverters
DV5, DV6 vector frequency inverters



Moeller HPL0211-2004/2005

		DV6-340-075	DV6-340-1K5	DV6-340-2K2
Control circuit				
Relays		1 × changeover contact, 230 V AC/0.2 A inductive load/2.5 A resistive load or 24 V DC/0.7 A inductive load/3 A resistive load		
Serial interface		RS 422, RS 485	RS 422, RS 485	RS 422, RS 485
Control voltage				
Output setpoint voltage	V	+10 DC, 20 mA	+10 DC, 20 mA	+10 DC, 20 mA
Output control voltage	V	+24 DC, 100 mA	+24 DC, 100 mA	+24 DC, 100 mA
Parameterization				
3 × parameter set (online/offline parameterization), parameter protection (programmable)				
Inputs				
Thermistor input		1 × PTC thermistor, thermostat		
Clockwise rotating field enable		1 × +24 V DC (input impedance 4.7 kΩ)		
Digital (configurable)		8 × +24 V DC (input impedance 4.7 kΩ)		
Analog, 12-bit resolution	Number	3 × 0 – +10 V DC, ±10 V DC (input impedance 10 kΩ), 4 – 20 mA (load impedance 100 Ω)		
Outputs				
Digital		5 × 24 V DC transistor (open-collector, max. 50 mA per output, configurable)		
Analog (configurable), 8-bit resolution		3 × 0 – +10 V DC (max. 2 mA), 4 – 20 mA (max. load impedance 250Ω)		
PWM (configurable)		1 × 0 – 10 V, max. 1.2 mA		
Terminal capacities				
Power cables	mm ²	1.5	2.5	2.5
	AWG	20	18	16
Relay connection	mm ²	0.14 – 1.5	0.14 – 1.5	0.14 – 1.5
	AWG	16 – 6	16 – 6	16 – 6
Control circuit	mm ²	0.14 – 1.5	0.14 – 1.5	0.14 – 1.5
	AWG	16 – 6	16 – 6	16 – 6

Notes

If the frequency inverter is to be installed in an enclosure, control panel or similar housing, the ambient temperature T_a is taken to be the temperature inside this enclosure or control panel. All rating data of the power section is based on a switching frequency of 5 kHz (default setting) and an ambient temperature of +40 °C, for operation of a four-pole three-phase asynchronous motor.

Moeller HPL0211-2004/2005

DV6-340-4K0	DV6-340-5K5	DV6-340-7K5	DV6-340-11K	DV6-340-15K	DV6-340-18K5
1 × changeover contact, 230 V AC/0.2 A inductive load/2.5 A resistive load or 24 V DC/0.7 A inductive load/3 A resistive load					
RS 422, RS 485	RS 422, RS 485	RS 422, RS 485	RS 422, RS 485	RS 422, RS 485	RS 422, RS 485
+10 DC, 20 mA	+10 DC, 20 mA	+10 DC, 20 mA	+10 DC, 20 mA	+10 DC, 20 mA	+10 DC, 20 mA
+24 DC, 100 mA	+24 DC, 100 mA	+24 DC, 100 mA	+24 DC, 100 mA	+24 DC, 100 mA	+24 DC, 100 mA
3 × parameter set (online/offline parameterization), parameter protection (programmable)					
Inputs					
1 × PTC thermistor, thermostat					
1 × +24 V DC (input impedance 4.7 kΩ)					
8 × +24 V DC (input impedance 4.7 kΩ)					
3 × 0 – +10 V DC, ±10 V DC (input impedance 10 kΩ), 4 – 20 mA (load impedance 100 Ω)					
Outputs					
5 × 24 V DC transistor (open-collector, max. 50 mA per output, configurable)					
3 × 0 – +10 V DC (max. 2 mA), 4 – 20 mA (max. load impedance 250Ω)					
1 × 0 – 10 V, max. 1.2 mA					
2.5	2.5	4	6	10	16
14	12	10	8	6	6
0.14 – 1.5	0.14 – 1.5	0.14 – 1.5	0.14 – 1.5	0.14 – 1.5	0.14 – 1.5
16 – 6	16 – 6	16 – 6	16 – 6	16 – 6	16 – 6
0.14 – 1.5	0.14 – 1.5	0.14 – 1.5	0.14 – 1.5	0.14 – 1.5	0.14 – 1.5
16 – 6	16 – 6	16 – 6	16 – 6	16 – 6	16 – 6



Moeller HPL0211-2004/2005

		DV6-340-22K	DV6-340-30K	DV6-340-37K
General				
Standards		EN 50178, IEC 61800-3, EN 61800-3 incl. A11		
Ambient temperature				
Operating temperature	°C	-10 to +40 at rated current I_e without derating, up to 50 at a reduced pulse frequency of 2 kHz and output current reduced to 80 % I_e		
Storage, transport	°C	-25 – +70		
Mechanical shock resistance		Vibration and impact, max. 5.9 m/s ² (0.6 g) at 10 to 55 Hz		
Pollution degree		VDE 0110 Part 2, pollution degree 2		
Climatic proofing		Class 3K3 according to EN 50178 (non-condensing, average relative humidity 20 to 90 %)		
Altitude	m	0 – 1000 above sea level		
Mounting position		Vertically suspended		
Free surrounding areas		100 mm above and below, 50 mm on each side		
Emitted interference		IEC/EN 61800-3 (EN 55011 group 1 class B)		
Noise immunity		IEC/EN 61800-3, industrial environment		
Insulation resistance		Overvoltage category III according to VDE 0110		
Leakage current to PE	mA	> 3.5 (according to EN 50178)		
Degree of protection		IP 20 (NEMA 1)		
Contact protection		Finger and back-of-hand proof (BGV A2)		
Protective isolation from switching circuitry		Safe isolation from the mains. Double basic isolation (according to EN 50178)		
Protective measures		Overcurrent, earth fault, overvoltage, undervoltage, overload, overtemperature, electronic overload protection: I^2t monitoring and PTC input (thermistor or thermostat)		
Heat dissipation at rated operational current I_e	W	115	1550	1900
Dimensions (w × h × d)	mm	256 × 396 × 210	310 × 540 × 202.2	390 × 550 × 255.2
Weight	kg	12	20	30
Power section				
Rated operational voltage	V AC	400	400	400
Rated voltage	U_e V	3 AC 342 – 528 V ± 0 %		
Supply frequency	Hz	50/60 (47 -0 % to 63 +0 %)		
Mains current				
$U_i = 400$ V AC three-phase	I A	53	63	83
Alternative DC supply	U_{DC} V DC	420 – 760		
Modulation method		Sensorless vector control, pulse width modulation (PWM)		
Switching frequency		5 kHz, adjustable from 0.5 to 15 kHz		
Output voltage	V	3 AC U_e	3 AC U_e	3 AC U_e
Output frequency	Hz	0.5 – 50, max. 400	0.5 – 50, max. 400	0.5 – 50, max. 400
Frequency resolution	Hz	0.1, with digital setpoint values/maximum frequency/1000 with analog setpoint values		
Frequency error threshold at 20 °C ± 10 K		±0.01 % of maximum frequency for digital reference values, ±0.2 % of maximum frequency for analog reference values		
Max. rated operational current	I_e A	48	58	75
Permissible overcurrent		150 % for 60 s/200 % for 0.5 s, every 600 s		
Torque during start		200 % at 0.5 Hz (sensorless vector control mode)		
Apparent power at 400 V	kVA	33.2	40.1	51.9
Apparent power at 480 V	kVA	39.9	48.2	62.3
Standard operation at 150 % overload Assigned motor rating (4-pole ASM)				
400 V	kW	22	30	37
460 V	HP	30	40	50

Notes If the frequency inverter is to be installed in an enclosure, control panel or similar housing, the ambient temperature T_a is taken to be the temperature inside this enclosure or control panel. All rating data of the power section is based on a switching frequency of 5 kHz (default setting) and an ambient temperature of +40 °C, for operation of a four-pole three-phase asynchronous motor.

Moeller HPL0211-2004/2005

		DV6-340-45K	DV6-340-55K	DV6-340-75K	DV6-340-90K	DV6-340-110K	DV6-340-132K
General							
Standards		EN 50178, IEC 61800-3, EN 61800-3 incl. A11					
Ambient temperature							
Operating temperature	°C	-10 to +40 at rated current I_e without derating, up to 50 at a reduced pulse frequency of 2 kHz and output current reduced to 80 % I_e					
Storage, transport	°C	-25 – +70					
Mechanical shock resistance		Vibration and impact, max. 2.94 m/s ² (0.3 g) at 10 to 55 Hz					
Pollution degree		VDE 0110 Part 2, pollution degree 2					
Climatic proofing		Class 3K3 according to EN 50178 (non-condensing, average relative humidity 20 to 90 %)					
Altitude	m	0 – 1000 above sea level					
Mounting position		Vertically suspended					
Free surrounding areas		100 mm above and below, 50 mm on each side					
Emitted interference		IEC/EN 61800-3 (EN 55011 group 1 class B)					
Noise immunity		IEC/EN 61800-3, industrial environment					
Insulation resistance		Overvoltage category III according to VDE 0110					
Leakage current to PE	mA	> 3.5 (according to EN 50178)					
Degree of protection		IP 20 (NEMA 1)					
Contact protection		Finger and back-of-hand proof (BGV A2)					
Protective isolation from switching circuitry		Safe isolation from the mains. Double basic isolation (according to EN 50178)					
Protective measures		Overcurrent, earth fault, overvoltage, undervoltage, overload, overtemperature, electronic overload protection: I^2t monitoring and PTC input (thermistor or thermostat)					
Heat dissipation at rated operational current I_e	W	2300	2800	3750	4500	5500	6500
Dimensions (w × h × d)	mm	390 × 550 × 255.2	390 × 550 × 255.2	390 × 700 × 275.2	390 × 700 × 275.2	480 × 740 × 293.2	480 × 740 × 293.2
Weight	kg	30	30	60	60	80	80
Power section							
Rated operational voltage	V AC	400	400	400	400	400	400
Rated voltage	U_e V	3 AC 342 – 528 V ± 0 %					
Supply frequency	Hz	50/60 (47 -0 % to 63 +0 %)					
Mains current							
$U_i = 400$ V AC three-phase	I A	99	121	164	194	239	286
Alternative DC supply	U_{DC} V DC	420 – 760					
Modulation method		Sensorless vector control, pulse width modulation (PWM)					
Switching frequency		5 kHz, adjustable from 0.5 to 15 kHz					
Output voltage	V	3 AC U_e	3 AC U_e	3 AC U_e	3 AC U_e	3 AC U_e	3 AC U_e
Output frequency	Hz	0.5 – 50, max. 400	0.5 – 50, max. 400	0.5 – 50, max. 400	0.5 – 50, max. 400	0.5 – 50, max. 400	0.5 – 50, max. 400
Frequency resolution	Hz	0.1, with digital setpoint values/maximum frequency/1000 with analog setpoint values					
Frequency error threshold at 20 °C ± 10 K		±0.01 % of maximum frequency for digital reference values, ±0.2 % of maximum frequency for analog reference values					
Max. rated operational current	I_e A	90	110	149	176	217	260
Permissible overcurrent		150 % for 60 s/200 % for 0.5 s, every 600 s					
Torque during start		200 % at 0.5 Hz (sensorless vector control mode)					
Apparent power at 400 V	kVA	62.3	76.2	103.2	121.9	150.3	180.1
Apparent power at 480 V	kVA	74.8	91.4	123.8	146.3	180.4	216.1
Standard operation at 150 % overload Assigned motor rating (4-pole ASM)							
400 V	kW	45	55	75	90	110	132
460 V	HP	60	75	100	125	150	175

Notes If the frequency inverter is to be installed in an enclosure, control panel or similar housing, the ambient temperature T_a is taken to be the temperature inside this enclosure or control panel. All rating data of the power section is based on a switching frequency of 5 kHz (default setting) and an ambient temperature of +40 °C, for operation of a four-pole three-phase asynchronous motor.



Moeller HPL0211-2004/2005

		DV6-340-22K	DV6-340-30K	DV6-340-37K
Control circuit				
Relays		1 × changeover contact, 230 V AC/0.2 A inductive load/2.5 A resistive load or 24 V DC/0.7 A inductive load/3 A resistive load		
Serial interface		RS 422, RS 485	RS 422, RS 485	RS 422, RS 485
Control voltage				
Output setpoint voltage	V	+10 DC, 20 mA	+10 DC, 20 mA	+10 DC, 20 mA
Output control voltage	V	+24 DC, 100 mA	+24 DC, 100 mA	+24 DC, 100 mA
Parameterization		3 × parameter set (online/offline parameterization), parameter protection (programmable)		
Inputs				
Thermistor input		1 × PTC thermistor, thermostat		
Clockwise rotating field enable		1 × +24 V DC (input impedance 4.7 kΩ)		
Digital (configurable) analog, 12-bit resolution	Number	8 × +24 V DC (input impedance 4.7 kΩ)		
		3 × 0 – +10 V DC, ±10 V DC (input impedance 10 kΩ), 4 – 20 mA (load impedance 100 Ω)		
Outputs				
Digital		5 × 24 V DC transistor (open-collector, max. 50 mA per output, configurable)		
Analog (configurable), 8-bit resolution		3 × 0 – +10 V DC (max. 2 mA), 4 – 20 mA (max. load impedance 250Ω)		
PWM (configurable)		1 × 0 – 10 V, max. 1.2 mA		
Terminal capacities				
Power cables	mm ²	16	25	35
	AWG	4	3	1
Relay connection	mm ²	0.14 – 1.5	0.14 – 1.5	0.14 – 1.5
	AWG	16 – 6	16 – 6	16 – 6
Control circuit	mm ²	0.14 – 1.5	0.14 – 1.5	0.14 – 1.5
	AWG	16 – 6	16 – 6	16 – 6

Notes
If the frequency inverter is to be installed in an enclosure, control panel or similar housing, the ambient temperature T_a is taken to be the temperature inside this enclosure or control panel. All rating data of the power section is based on a switching frequency of 5 kHz (default setting) and an ambient temperature of +40 °C, for operation of a four-pole three-phase asynchronous motor.

Moeller HPL0211-2004/2005

DV6-340-45K	DV6-340-55K	DV6-340-75K	DV6-340-90K	DV6-340-110K	DV6-340-132K
1 × changeover contact, 230 V AC/0.2 A inductive load/2.5 A resistive load or 24 V DC/0.7 A inductive load/3 A resistive load					
RS 422, RS 485	RS 422, RS 485	RS 422, RS 485	RS 422, RS 485	RS 422, RS 485	RS 422, RS 485
+10 DC, 20 mA	+10 DC, 20 mA	+10 DC, 20 mA	+10 DC, 20 mA	+10 DC, 20 mA	+10 DC, 20 mA
+24 DC, 100 mA	+24 DC, 100 mA	+24 DC, 100 mA	+24 DC, 100 mA	+24 DC, 100 mA	+24 DC, 100 mA
3 × parameter set (online/offline parameterization), parameter protection (programmable)					
Inputs					
1 × PTC thermistor, thermostat					
1 × +24 V DC (input impedance 4.7 kΩ)					
8 × +24 V DC (input impedance 4.7 kΩ)					
3 × 0 – +10 V DC, ±10 V DC (input impedance 10 kΩ), 4 – 20 mA (load impedance 100 Ω)					
Outputs					
5 × 24 V DC transistor (open-collector, max. 50 mA per output, configurable)					
3 × 0 – +10 V DC (max. 2 mA), 4 – 20 mA (max. load impedance 250Ω)					
1 × 0 – 10 V, max. 1.2 mA					
35	2 × 35	2 × 35	2 × 50	2 × 70	2 × 70
1	1/0	2 × 1	2 × 1	2 × 1/0	2 × 2/0
0.14 – 1.5	0.14 – 1.5	0.14 – 1.5	0.14 – 1.5	0.14 – 1.5	0.14 – 1.5
16 – 6	16 – 6	16 – 6	16 – 6	16 – 6	16 – 6
0.14 – 1.5	0.14 – 1.5	0.14 – 1.5	0.14 – 1.5	0.14 – 1.5	0.14 – 1.5
16 – 6	16 – 6	16 – 6	16 – 6	16 – 6	16 – 6

DF5, DF6 frequency inverters
DV5, DV6 vector frequency inverters

DF5, DF6 frequency inverters
DV5, DV6 vector frequency inverters





Application

When frequency inverters are operated in European Union (EU) member countries, conformance to EMC Directive 89/336/EEC is mandatory. The IEC/EN 61800-3 product standard for variable-speed drives regards a typical drive arrangement as a complete system, i.e. a combination of frequency inverter, cable and motor. Used with the listed radio frequency interference filters, the DF5, DV5, DF6 and DV6 frequency inverters meet with the requirements of the EMC product standard in industrial environments (second environment) and the more stringent limits for domestic environments (first environment).

First environment (public grid):

- Generally available:
 - Motor cable length up to 10 m and a maximum pulse frequency of 16 kHz
 - Motor cable length up to 20 m and a maximum pulse frequency of 5 kHz
- Limited availability:
 - Up to 50 m (according to product standard IEC/EN 61800-3, frequency inverters are products of limited availability. These products can cause radio frequency interference in domestic environments (public mains system, first environment). Users must implement suitable interference suppression measures.

Second environment (industrial):

- Generally available:
 - Up to 50 m
- Limited availability:
 - Up to 50 m

Features

- Ready for connection, with terminals and prefabricated connection cables for the assigned DF5, DV5, DF6 and DV6 frequency inverters.
- Book-type design for side mounting next to the frequency inverter. Up to and including 64 A (DE6-LZ3-064-V4), the filter can alternatively be footprint-mounted underneath the frequency inverter.
- EMC conformity for the DF5, DV5, DF6 and DV6 frequency inverters:
 - Emitted interference, IEC/EN 61800-3 (EN 55011 Group 1, Class B)
 - Interference immunity, IEC/EN 61800-3, industrial environment

Function

Radio interference suppression filters protect against conducted high-frequency interference (noise immunity) and reduce the high-frequency interference from a device, which is transmitted through or emitted from the mains cable, and which must be limited to a prescribed level (emitted interference).

Radio interference suppression filters must be installed as near as possible to the frequency inverter.

Filters have earth leakage currents. In the event of a malfunction (such as phase failure or load unbalance) these can rise some way above the nominal values. To avoid dangerous voltages, the filters must therefore be earthed before they are switched on.

For leakage currents above 3.5 mA, VDE 0160 and EN 60335 stipulate the following:

- The protective conductor must have a cross-section $\geq 10 \text{ mm}^2$

or

- the protective conductor must be open-circuit monitored

or

- an additional conductor must be fitted.

As these leakage currents are high-frequency interference, the earthing conductors must have a low impedance and a large surface area.

Documentation

Each filter is supplied with installation and connection instructions (AWA).

For information about EMC-compliant installation, see the manuals for the respective frequency inverters.



Keypads, connection cables, interface modules, enclosures

Moeller HPL0211-2004/2005

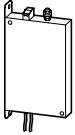
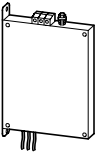
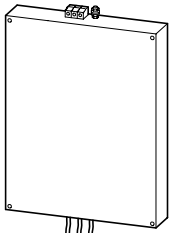
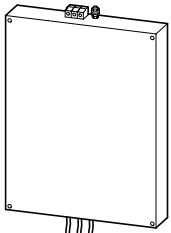
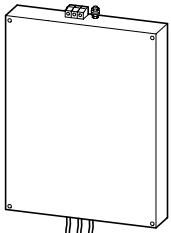
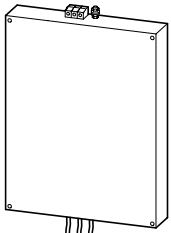
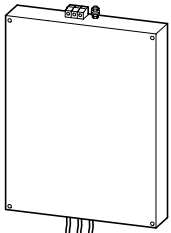
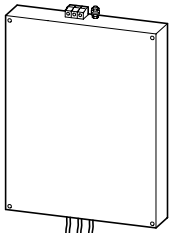
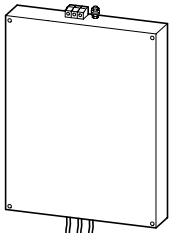
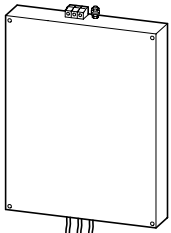
	Rated voltage U_e V	Assigned frequency inverter		Type Article no.	Price See Price List	Std. pack
		DF5 DF6	DV5 DV6			
Radio interference suppression filters						
	1 AC 180 – 252 V ±0 %	DF5-322-018	DV5-322-018	DE5-LZ1-007-V2 232352	1 off	
		DF5-322-037	DV5-322-037 DV5-322-055			
		DF5-322-055	DV5-322-075	DE5-LZ1-012-V2 232353		
	3 AC 342 – 506 V ±0 %	DF5-322-1K1	DV5-322-1K5	DE5-LZ1-024-V2 232354	1 off	
		DF5-322-1K5	DV5-322-2K2			
		DF5-322-2K2				
	3 AC 342 – 528 V ±0 %	DF5-340-037	DV5-340-037	DE5-LZ3-007-V4 232355	1 off	
		DF5-340-075	DV5-340-075 DV5-340-1K5 DV5-340-2K2			
		DF5-340-1K5				
	3 AC 342 – 528 V ±0 %	DF5-340-2K2	DV5-340-3K0	DE5-LZ3-011-V4 232356	1 off	
		DF5-340-3K0	DV5-340-4K0			
		DF5-340-4K0				
	3 AC 342 – 528 V ±0 %	DF5-340-5K5	DV5-340-5K5	DE5-LZ3-020-V4 232357	1 off	
		DF5-340-7K5	DV5-340-7K5			
		–				
	3 AC 342 – 528 V ±0 %	DF6-340-075	DV6-340-075	DE6-LZ3-013-V4 232358	1 off	
		DF6-340-1K5	DV6-340-1K5 DV6-340-2K2 DV6-340-4K0 DV6-340-5K5			
		DF6-340-11K	DV6-340-7K5	DE6-LZ3-032-V4 232359		
	3 AC 342 – 528 V ±0 %	DF6-340-15K	DV6-340-11K	DE6-LZ3-064-V4 232360	1 off	
		DF6-340-18K5	DV6-340-15K			
		DF6-340-22K	DV6-340-18K5			
	3 AC 342 – 528 V ±0 %	DF6-340-30K	DV6-340-22K	DE6-LZ3-080-V4¹⁾ 232361	1 off	
		DF6-340-37K	DV6-340-30K			
		DF6-340-45K	DV6-340-37K	DE6-LZ3-115-V4¹⁾ 232362		
	3 AC 342 – 528 V ±0 %	DF6-340-55K	DV6-340-45K	DE6-LZ3-125-V4¹⁾ 232363	1 off	
		–	DV6-340-55K			
		DF6-340-75K	–	DE6-LZ3-150-V4¹⁾ 233181		
	3 AC 342 – 528 V ±0 %	DF6-340-90K	DV6-340-75K	DE6-LZ3-220-V4¹⁾ 233182	1 off	
		DF6-340-110K	DV6-340-90K			
		DF6-340-132K	DV6-340-110K	DE6-LZ3-260-V4¹⁾ 233183		
		DF6-340-132K	DV6-340-132K			

Notes

¹⁾ Only for side-mounting next to frequency inverter.

DF5, DF6 frequency inverters
DV5, DV6 vector frequency inverters



Moeller HPL0211-2004/2005

		DE5-LZ1-007-V2	DE5-LZ1-012-V2	DE5-LZ1-024-V2
General				
Standards		EN 50178, IEC 61800-3, EN 61800-3 incl. A11		
Environmental conditions				
Operating temperature	°C	-25 – +85	-25 – +85	-25 – +85
Altitude	m	0 – 1000 a.s.l., derating above 1000: $I_e - 2\%/1000\text{ m}$		
Mounting position		As required, vertically suspended preferred		
Free surrounding areas		In connection area (cable, terminals): 100 mm		
Humidity class		C	C	C
Degree of protection		IP 20 (terminals)	IP 20 (terminals)	IP 20 (terminals)
Dimensions (w × h × d)	mm	80 × 155 × 27	110 × 165 × 27	140 × 215 × 29
Weight	kg	0.5	0.7	1
Electrical data				
Test voltage in V DC, 2 s				
Phase/phase	V	1400	1400	1400
Phase/PE	V	2800	2800	1400
Leakage current to PE				
Phase/50 Hz/ U_i	mA	< 3.5	< 3.5	< 15
Phase/50 Hz/ $U_i = 460\text{ V}$, (failure of two phases, worst case)	mA	–	–	–
Rated operational voltage	V AC	230	230	230
Rated voltage	U_e V	1 AC 180 – 252 V ± 0 %	1 AC 180 – 252 V ± 0 %	1 AC 180 – 252 V ± 0 %
Supply frequency	Hz	50/60 (47 -0 % to 63 +0 %)	50/60 (47 -0 % to 63 +0 %)	50/60 (47 -0 % to 63 +0 %)
Rated operational current				
$U_i = 230\text{ V AC single-phase}$	I A	7	12	24
$U_i = 400\text{ V AC three-phase}$	I A	–	–	–
Permissible overcurrent		150 % for 10 minutes	150 % for 10 minutes	150 % for 10 minutes
Heat dissipation at rated operational current I_e	W	6	7	9
Terminal capacities				
Solid	mm ²	4	4	4
Flexible	mm ²	4	4	4
Cables to frequency inverter	mm ²	2 × 1.5	2 × 1.5	2 × 2.5
PE stud		M5	M5	M5

Notes

All rating data assumes an ambient temperature of +40 °C.

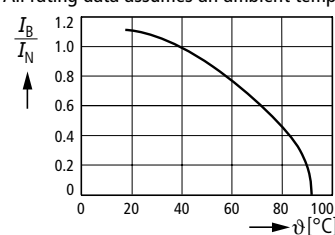

Moeller HPL0211-2004/2005

		DE5-LZ3-007-V4	DE5-LZ3-011-V4	DE5-LZ3-020-V4
General				
Standards		EN 50178, IEC 61800-3, EN 61800-3 incl. A11		
Environmental conditions				
Operating temperature	°C	-25 – +85	-25 – +85	-25 – +85
Altitude	m	0 – 1000 a.s.l., derating above 1000: $I_e - 2\%/1000\text{ m}$		
Mounting position		As required, vertically suspended preferred		
Free surrounding areas		In connection area (cable, terminals): 100 mm		
Humidity class		C	C	C
Degree of protection		IP 20 (terminals)	IP 20 (terminals)	IP 20 (terminals)
Dimensions (w × h × d)	mm	110 × 160 × 27	140 × 210 × 31	182 × 287 × 35
Weight	kg	0.8	1.1	2.4
Electrical data				
Test voltage in V DC, 2 s				
Phase/phase	V	1978	1978	1978
Phase/PE	V	2800	2800	1978
Leakage current to PE				
Phase/50 Hz/ U_i	mA	< 3.5	< 3.5	< 10
Phase/50 Hz/ $U_i = 460\text{ V}$, (failure of two phases, worst case)	mA	32	62	120
Rated operational voltage	V AC	400	400	400
Rated voltage	U_e V	3 AC 342 – 506 V ± 0 %	3 AC 342 – 506 V ± 0 %	3 AC 342 – 506 V ± 0 %
Supply frequency	Hz	50/60 (47 -0 % to 63 +0 %)	50/60 (47 -0 % to 63 +0 %)	50/60 (47 -0 % to 63 +0 %)
Rated operational current				
$U_i = 230\text{ V AC single-phase}$	I A	–	–	–
$U_i = 400\text{ V AC three-phase}$	I A	7	11	20
Permissible overcurrent		150 % for 10 minutes	150 % for 10 minutes	150 % for 10 minutes
Heat dissipation at rated operational current I_e	W	7	10	14
Terminal capacities				
Solid	mm ²	4	4	4
Flexible	mm ²	4	4	4
Cables to frequency inverter	mm ²	3 × 1.5	3 × 2.5	3 × 2.5
PE stud		M5	M5	M5



Moeller HPL0211-2004/2005

		DE6-LZ3-013-V4	DE6-LZ3-032-V4	DE6-LZ3-064-V4
General				
Standards		EN 50178, IEC 61800-3, EN 61800-3 incl. A11		
Environmental conditions				
Operating temperature	°C	-25 – +85	-25 – +85	-25 – +85
Altitude	m	0 – 1000 a.s.l., derating above 1000: $I_e - 2\%/1000\text{ m}$		
Mounting position		As required, vertically suspended preferred		
Free surrounding areas		In connection area (cable, terminals): 100 mm		
Humidity class		C	C	C
Degree of protection		IP 20 (terminals)		
Dimensions (w × h × d)	mm	143 × 255 × 29	203 × 260 × 43	244 × 390 × 45
Weight	kg	1.4	2.5	4.5
Electrical data				
Test voltage in V DC, 2 s				
Phase/phase	V	2064	2064	2064
Phase/PE	V	2064	2064	2064
Leakage current to PE				
Phase/50 Hz/ U_i	mA	< 30	< 30	< 30
Phase/50 Hz/ $U_i = 460\text{ V}$, (failure of two phases, worst case)	mA	180	280	550
Rated operational voltage	V AC	400	400	400
Rated voltage	U_e V	3 AC 342 – 528 V ±0 %	3 AC 342 – 528 V ±0 %	3 AC 342 – 528 V ±0 %
Supply frequency	Hz	50/60 (47 -0 % to 63 +0 %)		
Rated operational current				
$U_i = 400\text{ V AC}$ three-phase	I A	13	32	64
Permissible overcurrent		150 % for 10 minutes		
Heat dissipation at rated operational current I_e				
	W	12	14	36
Terminal capacities				
Solid	mm ²	4	10	25
Flexible	mm ²	4	6	16
Cables to frequency inverter	mm ²	3 × 2.5	3 × 6	3 × 16
PE stud		M5	M5	M8

Notes

All rating data assumes an ambient temperature of +40 °C.

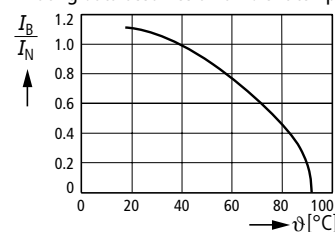

Moeller HPL0211-2004/2005

DE6-LZ3-080-V4	DE6-LZ3-115-V4	DE6-LZ3-125-V4	DE6-LZ3-150-V4	DE6-LZ3-220-V4	DE6-LZ3-260-V4
EN 50178, IEC 61800-3, EN 61800-3 incl. A11					
Environmental conditions					
-25 – +85	-25 – +85	-25 – +85	-25 – +85	-25 – +85	-25 – +85
0 – 1000 a.s.l., derating above 1000: $I_e - 2\%/1000\text{ m}$					
As required, vertically suspended preferred					
In connection area (cable, terminals): 100 mm					
C	C	C	C	C	C
IP 20 (terminals)					
60 × 400 × 87	70 × 440 × 110	70 × 440 × 110	130 × 525 × 94	130 × 525 × 94	142 × 620 × 116
4.3	6.4	6.7	8.8	9.3	13.7
Test voltage in V DC, 2 s					
2064	2064	2064	2064	2064	2064
2064	2064	2064	2064	2064	2064
Leakage current to PE					
< 30	< 30	< 30	< 30	< 30	< 30
690	750	750	380	380	600
400	400	400	400	400	400
3 AC 342 – 528 V ±0 %	3 AC 342 – 528 V ±0 %	3 AC 342 – 528 V ±0 %	3 AC 342 – 528 V ±0 %	3 AC 342 – 528 V ±0 %	3 AC 342 – 528 V ±0 %
50/60 (47 -0 % to 63 +0 %)					
80	115	125	150	220	260
150 % for 10 minutes	150 % for 10 minutes	150 % for 10 minutes	150 % for 10 minutes	150 % for 10 minutes	150 % for 10 minutes
32	38	45	45	35	45
35	50	50	95	95	95
25	50	50	95	95	95
3 × 16	3 × 35	3 × 35	3 × 50	3 × 70	3 × 95
M8	M10	M10	M10	M10	M12



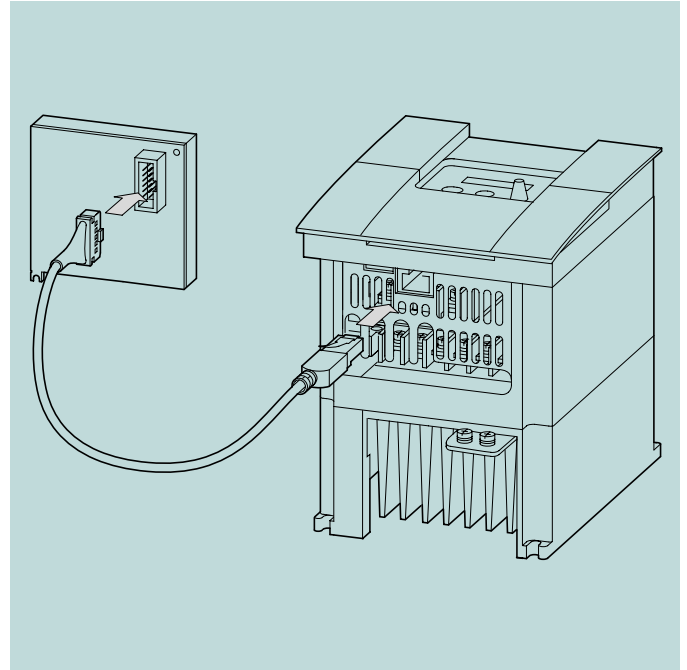

Type overview

DE5-KEY-RO3

External display unit for DF5 and DV5

Application

External display unit for DF5 and DV5 frequency inverters. DE5-KEY-RO3 can be installed on a control panel enclosure. The frequency inverter is connected through the RS 422 interface.

Note:
The connectors must be connected and disconnected only under no-voltage conditions.

Required accessories: DE5-CBL-...-ICL connection cable

Features

- 14 mm high, three-digit 7-segment LED display
- POWER display
- STOP button
- Degree of protection IP 54 (front)

Function

The value displayed on the DE5-KEY-RO3 may deviate from the value shown on the frequency inverter's keypad display. By default, the frequency inverter's output frequency in Hz is displayed. The display can be changed over through the frequency inverter's keypad, e.g.: motor current (parameter PNU b89). The STOP button can be disabled with parameter PNU b87. The POWER LED indicates when the respective frequency inverter is live.

Documentation

Installation and connection instructions (AWA) are included with each display unit. Information about configuring the display can be found in the manuals of the respective frequency inverter.

Type overview

DE5-CBL-0M5-ICL
DE5-CBL-1M0-ICL

Connection cables for DE5-KEY-RO3 display unit

Application

Prefabricated connection cable for direct connection of the DE5-KEY-RO3 external keypad to a DF5 frequency inverter or DV5 vector frequency inverter.

Features

- Cable, length 50 cm: DE5-CBL-0M5-ICL
- Cable, length 1 m: DE5-CBL-1M0-ICL

Function

Connection via RS 422 interface

Note:
The connectors must be connected and disconnected only under no-voltage conditions.



DEX-KEY-10 keypads, DEX-CBL-...-ICS connection cables

Moeller HPL0211-2004/2005

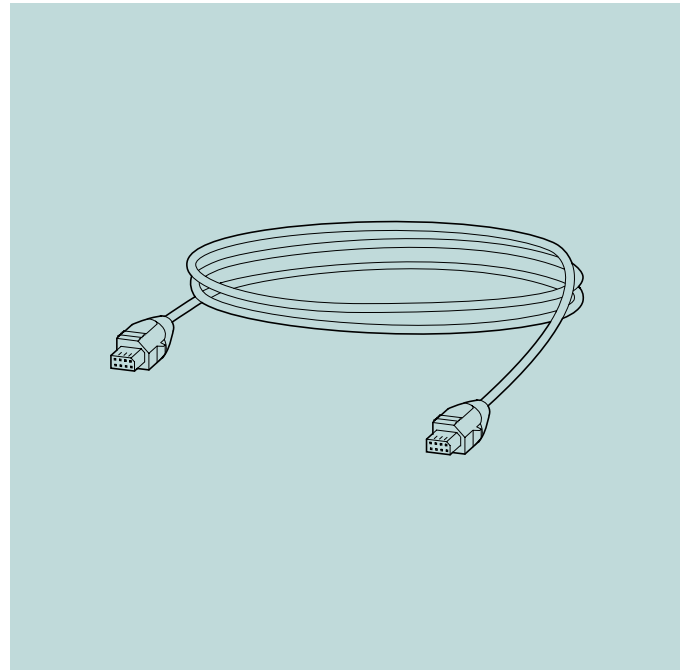

Type overview

DEX-KEY-10

External keypad with configuration memory

Application

Optional keypad with non-volatile configuration memory for the DF5, DV5, DF6 and DV6 frequency inverters.

The DEX-KEY-10 can be surface-mounted on a control panel housing or fitted to the DF6 and DV6 frequency inverters as an alternative to the standard keypad. It is connected to the frequency inverter through the RS 422 interface.

Note:

The RS 232 connectors must be connected and disconnected only under no-voltage conditions.

For external mounting, a connection cable with RJ45 plugs (DEX-CBL-...-ICS) is required.

Features

Two-line, background-lit LCD display

- LED function messages
- Plain text display, in one of six languages (English, French, German, Italian, Portuguese, Spanish) with DF6 and DV6, and in English with DF5 and DV5.
- START/STOP and configuration keys
- Degree of protection: operating side (front) IP 54, NEMA 12

Function

With the DEX-KEY-10 keypad, all parameters can be edited. They can be saved and transferred to frequency inverters of the same type (Copy function, non-volatile memory).

Parameters, setpoint values and actual values are displayed in English on a single line with the DF5 and DV5 frequency inverters.

With the DF6 and DV6 devices, two display lines are used and the display language can be selected.

Documentation

Installation and connection instructions (AWA) are included with each unit. For notes about parameterization, see manual AWB8240-1416, which is contained on the CD supplied with all DF5, DF6, DV5 and DV6 frequency inverters. The documentation is also available on the Internet: <ftp://ftp.moeller.net/DRIVES/index.html>.

Type overview

DEX-CBL-1M0-ICS
DEX-CBL-3M0-ICS

Connection cables for keypads

Application

Prefabricated connection cable with RJ45 plug for direct connection of:

- DF6 and DV6 frequency inverters for projecting positioning (external surface mounting) of the connected keypad
- the external DEX-KEY-10 keypad with DF5, DV5, DF6 and DV6 frequency inverters

Features

- Cable, length 1 m: DEX-CBL-1M0-ICS
- Cable, length 3 m: DEX-CBL-3M0-ICS
- RJ45 with protection against direct contact

Function

Connection via RS 422 interface

Note:

The RS 232 connectors must be connected and disconnected only under no-voltage conditions.



18/64 Description

DE6-IOM-ENC encoder interface card

Moeller HPL0211-2004/2005

DF5, DF6 frequency inverters
DV5, DV6 vector frequency inverters

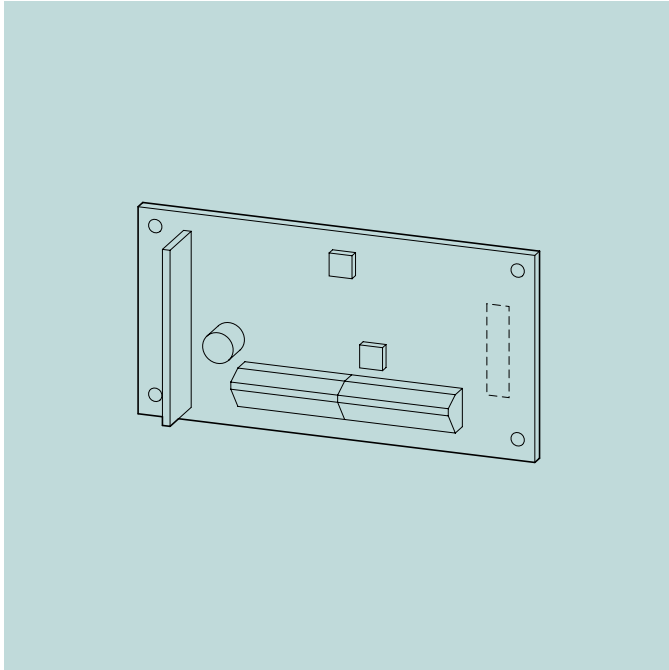

Synchronous operation and ratio control M1:M2 = 5:1

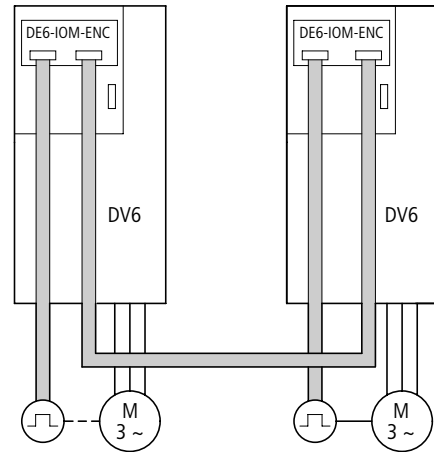

Features

- Simply plugs into a slot in the DV6 frequency inverter

Note:

- The card must be fitted and pulled only under no-voltage conditions.
- Parameterization via the DV6 frequency inverter's menu.
- Encoder connection via screw terminals.

Function

- Output voltage (power supply) for the encoder: 5 V DC, 150 mA.
- Max. number of input pulses: 65,000
- Input: two TTL signals offset by 90° (5 V DC, RS 422 standard) with zero pulse and inverted signals.

Type overview

DE6-IOM-ENC

Encoder card for DV6 frequency inverters

Application

The DE6-IOM-ENC card can be used in conjunction with the DV6 vector frequency inverters and enables speed control of three-phase motors with a directly connected encoder.

Further application features are:

- Synchro control and ratio control
- Motor standstill recognition
- Torque regulation

Speed control:

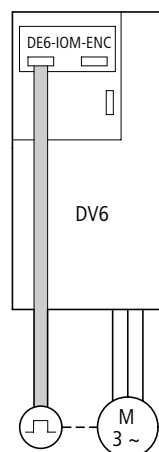

Encoder

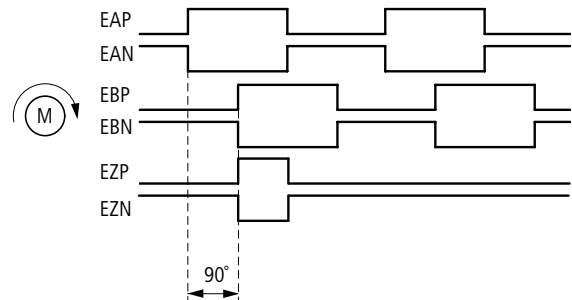

Documentation

Installation and connection instructions (AWA) are included with each encoder card. The manual for the encoder card (AWB8240-1431) is contained on the CD supplied with every DV6 frequency inverter.

The documentation is also available on the Internet at <ftp://ftp.moeller.net/DRIVES/index.html>.



DE5-NET-DP PROFIBUS DP interface module, DE5-MNT-BX enclosure

Moeller HPL0211-2004/2005

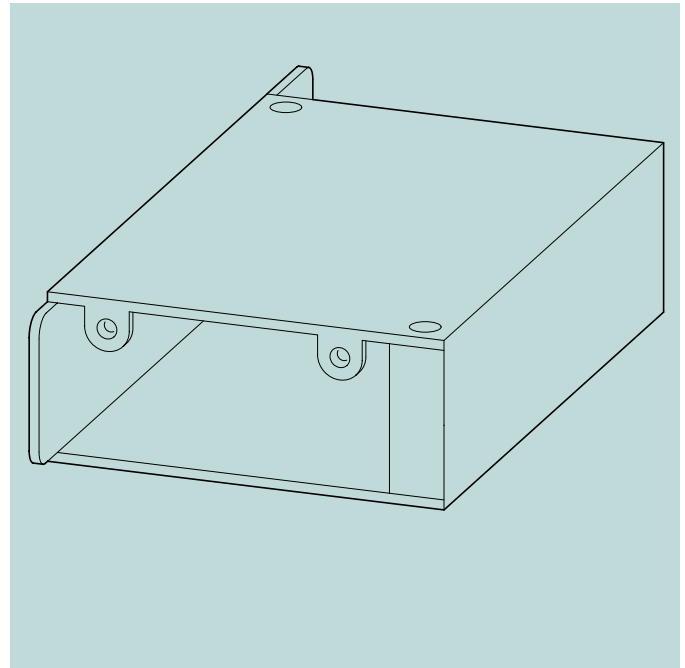
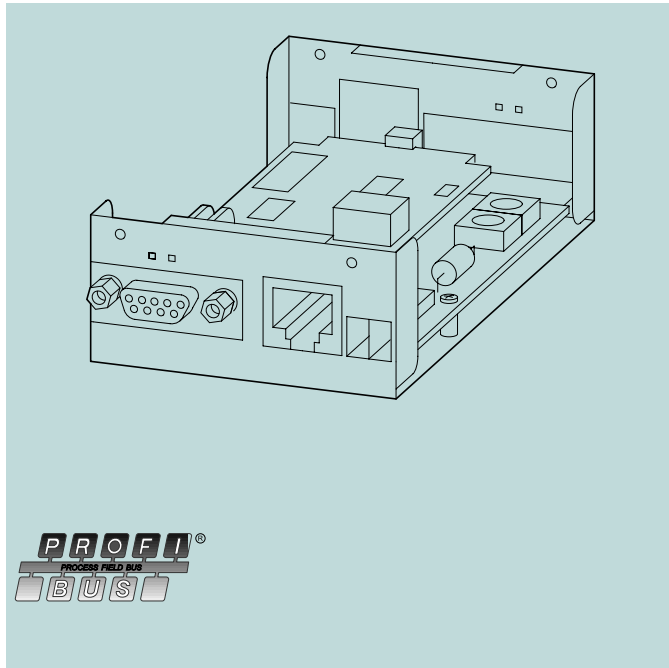

Type overview

DE5-NET-DP

Interface for PROFIBUS DP networks

Application

The DE5-NET-DP provides an interface for DF5 and DV5 frequency inverters to systems and plants with the standardized PROFIBUS DP fieldbus.

Features

- For mounting underneath or next to the frequency inverter
- Intelligent modules with their own processor and with potential isolation
- RS 485 interface (9-pin, D-SUB socket)
- Device address set with two rotary switches
- Data transfer: 9.6 Kbit/s (at 1,200 m) to 12 Mbit/s (at 100 m) with automatic baud rate detection

Documentation

A mounting and connection guide (AWA8240-1941) is supplied with each DE5-NET-DP PROFIBUS DP module. For notes about parameterization, see manual AWB8240-1417, which is contained on the CD supplied with all DF5, DF6, DV5 and DV6 frequency inverters. You will also find the required GSD file here. The documentation is also available on the Internet at <ftp://ftp.moeller.net/DRIVES/index.html>.

Notes

The connection cable (0.3 m) for the frequency inverter is included.
Required mounting accessories: DE5-MNT-BX... enclosure

Type overview

DE5-MNT-BX1

Enclosure for DE5-NET-DP PROFIBUS DP interface module

Installation possibilities:

- Underneath the frequency inverter (footprint-mounting; only for frequency inverters DF5-322-018/-037 and DV5-322-018 to -055)

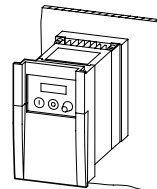

- Side-mounting

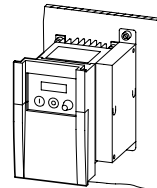

18/66 Description

DE6-NET-DP PROFIBUS DP interface card

Moeller HPL0211-2004/2005

DF5, DF6 frequency inverters
DV5, DV6 vector frequency inverters

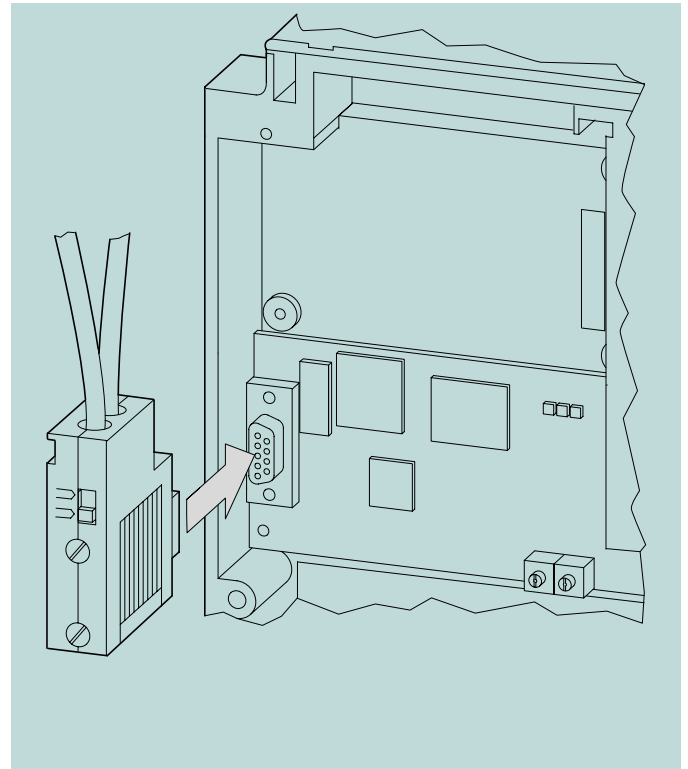
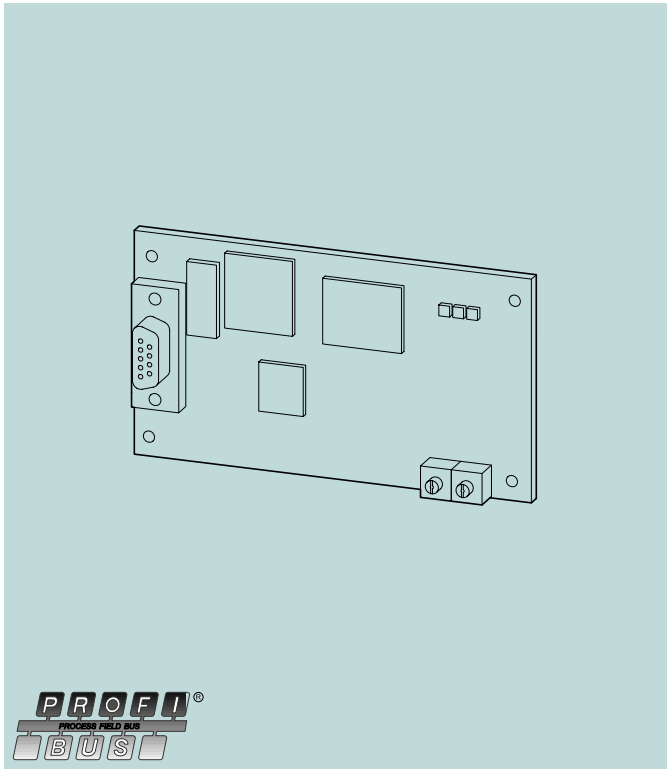

Type overview

DE6-NET-DP

Interface for PROFIBUS DP networks

Application

The DE6-NET-DP provides an interface for DF6 and DV6 frequency inverters to systems and plants with the standardized PROFIBUS DP fieldbus.

Features

- Installation in slot 2 of DF6 or DV6 frequency inverter
- Intelligent modules with their own processor and with potential isolation
- RS 485 interface (9-pin, D-SUB socket)
- Device address set with two rotary switches
- Data transfer: 9.6 Kbit/s (at 1,200 m) to 12 Mbit/s (at 100 m) with automatic baud rate detection
- PROFIDrive profile, drive engineering version 2

Documentation

A mounting and connection guide (AWA8240-1942) is supplied with each DE6-NET-DP PROFIBUS DP module. For notes about parameterization, see manual AWB8240-1418, which is contained on the CD supplied with all DF5, DF6, DV5 and DV6 frequency inverters. The documentation is also available on the Internet at <ftp://ftp.moeller.net/DRIVES/index.html>.



Moeller HPL0211-2004/2005

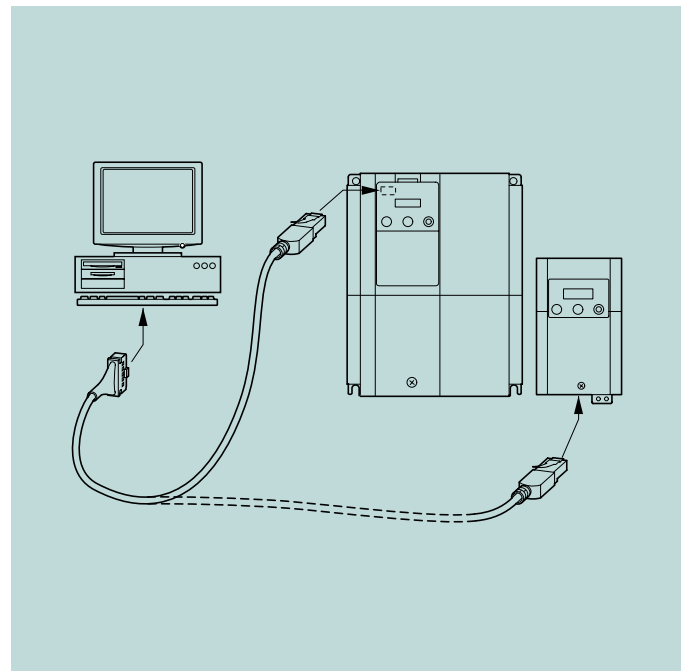
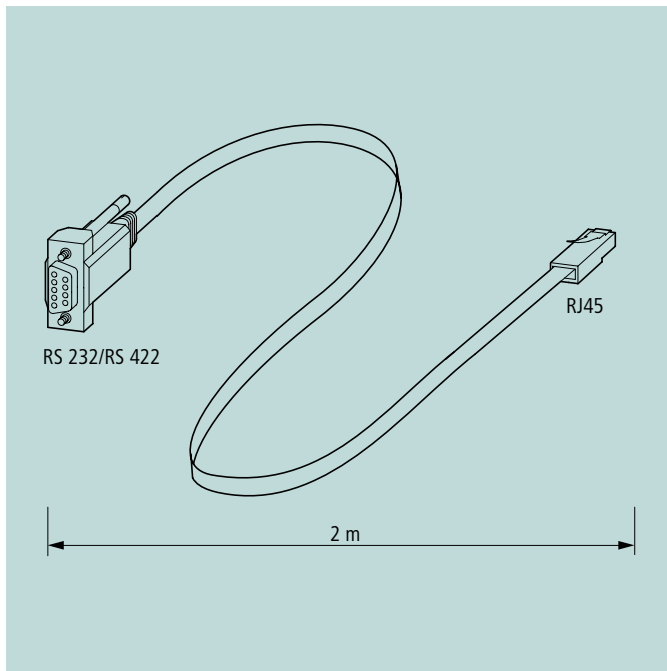

DF5, DF6 frequency inverters
DV5, DV6 vector frequency inverters

Type overview

DEX-CBL-2M0-PC

Connection cable with interface converter

Application

Prefabricated connection cable with interface converter (RS 232/RS 422) for connecting a PC to a DF5, DV5, DF6 or DV6 frequency inverter.

Note:

The connectors must be connected and disconnected only under no-voltage conditions.

Features

- Cable, length 2 m
- RS 232 (9-pin SUB-D socket)
- RS 422 (RJ45 plug)
- Point-to-point connection

Function

With the DEX-CBL-2M0-PC connection cable, a PC can be directly connected to a DF5, DV5, DF6 or DV6 frequency inverter.

With the parameterization software (included with the frequency inverter), simple data access to all parameters is possible. Precondition: Windows operating system (98, ME, NT, 2000, or XP).

Documentation

Installation and connection instructions (AWA) are included with each display unit. Information about parameterization can be found in the manual of the respective frequency inverters or the help texts of the Drives-Soft software.

Note

Drives-Soft is contained on the CD supplied with each DF5, DV5, DF6 and DV6 frequency inverter.





Type overview

DE4-BU4-1 braking unit

Braking unit for controlling external braking resistors

Application

Braking units with assigned braking resistors are used for rapid braking of frequency-controlled three-phase drives. With its integrated synchronization, the DE4-BU4-1 allows several braking units to be operated in parallel, for example for large loads (lifting gear).

Features

- Braking transistor with automatic control (adjustable response value)
- Braking resistors (DE4-BR1...) are not supplied with the device. The lowest permissible resistance is 18 Ω
- Synchronization for parallel operation of several DE4-BU... at high braking power.
- Continuous braking power up to 18 kW
- Maximum braking power 30 kW, with 15 s make time and 150 s pause time

Function

With short braking times, the frequency controlled motor operates in regenerative (oversynchronous) mode. In this mode, it feeds power into the frequency inverter's DC link, which results in an increased DC bus voltage. If the voltage exceeds the permitted limit value, the frequency inverter control logic disables the frequency inverter's power inverter and the motor coasts to a stop. If one or more braking units are connected in parallel to the internal DC link, the recovered energy can be diverted through the assigned braking resistors, where it is dissipated as heat.

Documentation

See <ftp://ftp.moeller.net/DRIVES/index.html>



Type overview

DE4-BR1...

Braking resistors

Application

An external braking resistor is required when braking large moments of inertia or when operating in extended regenerative mode. It converts the mechanical braking energy to heat.

Function

The integral braking transistor of the frequency inverter automatically diverts energy to the connected braking resistor when the threshold value of the DC bus voltage is exceeded. This prevents overvoltages in the DC link, which would otherwise cause an "overvoltage" fault message and activate the pulse inhibitor of the frequency inverter. The drive coasts to a stop.

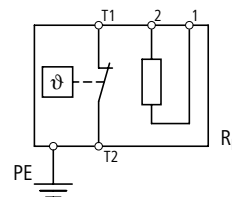

Features

The resistors are built into a perforated sheet-metal enclosure and are fitted with an overtemperature protection switch (230 V, 1A, AC-1). The enclosure is made from galvanized perforated sheet metal, is open at the base and conforms to IP 20 degree of protection when installed.



Moeller HPL0211-2004/2005

**Type overview****DEXLN1...**

Mains chokes, single-phase

Application

Mains chokes – also called commutating chokes – are connected in series on the mains input side of electronic equipment.

Function

Mains chokes limit the inrush current and dampen current harmonics and any additional current peaks. By dampening the harmonic currents, the r.m.s value of the input current can be reduced by up to 30 %. Mains chokes also guarantee the frequently required short-circuit voltage (u_k value) of about 4 % relative to the mains voltage.

Mains chokes extend components' lifespan (rectifier diodes, DC link capacitors) on equipment with input-side DC link (frequency inverters, UPS).

Features

The mains chokes are vacuum-impregnated for low-noise operation. They offer low-fatigue, magnetically and metallically neutral air-gap bypasses. Because of their flux distribution, the clearance to metal parts and neighbouring components must be at least 50 mm.

**Type overview****DEXLN3...**

Mains chokes, three-phase

Application

Mains chokes – also called commutating chokes – are connected in series on the mains input side of electronic equipment.

Function

Mains chokes limit the inrush current and dampen current harmonics and any additional current peaks. By dampening the harmonic currents, the r.m.s value of the input current can be reduced by up to 30 %. Mains chokes also guarantee the frequently required short-circuit voltage (u_k value) of about 4 % relative to the mains voltage.

Mains chokes extend components' lifespan (rectifier diodes, DC link capacitors) on equipment with input-side DC link (frequency inverters, UPS).

Features

The mains chokes are vacuum-impregnated for low-noise operation. They offer low-fatigue, magnetically and metallically neutral air-gap bypasses. Because of their flux distribution, the clearance to metal parts and neighbouring components must be at least 50 mm.



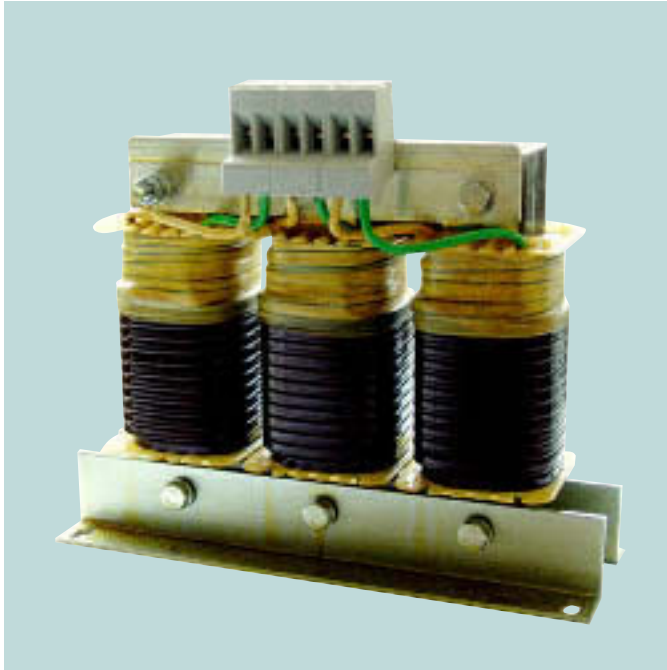

Type overview

DEXLM3...

Motor chokes, single-phase

Application

Motor chokes are used on the output of the frequency inverters in series with the motor.

Function

Motor chokes reduce the slew rate of the output voltage ($du/dt < 500 \text{ V}/\mu\text{s}$), as well as motor noise and heating. The use of motor chokes enables the permissible motor cable lengths to be extended up to 200 m.

Features

The motor chokes are vacuum-impregnated for low-noise operation. They offer low-fatigue, magnetically and metallurgically neutral air-gap bypasses. Because of their flux distribution, the clearance to metal parts and neighbouring components must be at least 50 mm.

Description

The following are available:

- 1 K
- 4.7 K
- 10 K

Features

- M22-.K.: Resistance value 1/4.7/10 [k Ω]
- Angle of rotation: $270^\circ \pm 5^\circ$
- Degree of protection: IP 66
- Power: max. 0.5 W
- Linearity: $\pm 0.5 \%$
- Voltage rating: 250 V AC

Notes



Wiring of M22-.K.. and PR10... potentiometers:

- The connecting cables to the potentiometers should be screened.
- The cable screen should be connected at one end near the frequency inverter and isolated at the potentiometer (with a rubber grommet).
- The potentiometer is connected via screw terminals (M22-.K..) and soldering lugs (PR10...).

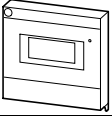
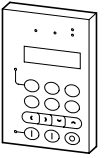
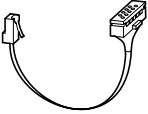
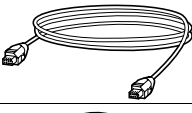

Keypads, connection cables, interface modules, enclosures

Moeller HPL0211-2004/2005

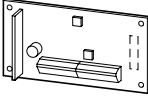
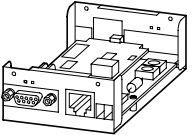
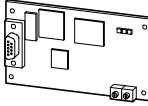
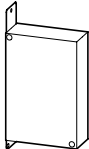
	For use with		Type Article no.	Price See Price	Std. pack
Keypads					
	DF5-.../DV5-... RA-SP	External display	DE5-KEY-R03 232372		1 off
	DF5-... DF6-... DV5-... DV6-... RA-SP	Keypad with memory	DEX-KEY-10 231421		1 off
Connection cable					
	DE5-KEY-R03	Connection cable (0.5 m)	DE5-CBL-0M5-ICL 232373		1 off
	DE5-KEY-R03	Connection cable (1.0 m)	DE5-CBL-1M0-ICL 232374		
	DEX-KEY-10	Connection cable (1.0 m)	DEX-CBL-1M0-ICS 232375		
	DEX-KEY-10	Connection cable (3.0 m)	DEX-CBL-3M0-ICS 232376		
	PC interfacing	Connection cable with converter, RS 232/422	DEX-CBL-2M0-PC 233184		
Interface modules					
DE6-IOM-ENC encoder interface card					
	DV6-...	Encoder interface card	DE6-IOM-ENC 232365		1 off
DE5-NET-DP PROFIBUS DP interface module					
	DF5-.../DV5-...	External PROFIBUS DP interface for DF5 frequency inverters and DV5 vector frequency inverters incl. connection cable (0.3 m) to frequency inverter. Note: Enclosure DE5-MNT-BX1 required.	DE5-NET-DP 232377		1 off
DE6-NET-DP PROFIBUS DP interface card					
	DF6-.../DV6-...	PROFIBUS DP interface card for DF6 frequency inverters and DV6 vector frequency inverters. The module is built into the device.	DE6-NET-DP 232369		1 off
DE5-MNT-BX1 enclosure					
For DE5-NET-DP interface module					
	DF5-322-018	–	DE5-MNT-BX1 258436		1 off



18/72 Accessories

Braking unit

Moeller HPL0211-2004/2005

DF5, DF6 frequency inverters
DV5, DV6 vector frequency inverters

Frequency inverter	Braking unit					Type Article no.	Price See Price List	Std. pack
	Mains voltage (45 – 65 Hz)	Minimum braking resistance	Maximum braking current	Continuous braking power at U_{LN}				
U_{LN} V	R_{min} Ω	I A DC	At 230 V P W	At 400 V P W	P_{max} kW			

Braking unit

For faster braking of frequency-controlled three-phase drives. The external braking resistor can be used for setting the braking power through exchange of the existing braking resistor or connection of a further resistor in series or in parallel.

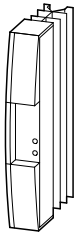

400/460	18 (external)	–	9000	18000	30			
---------	---------------	---	------	-------	----	--	--	--

DE4-BU4-1
085035

1 off

Notes The rating applies for an operating time of 15 s and an off period of 150 s.

		Type Article no.	Price See Price List	Std. pack
Documentation				
Documentation for accessories must be ordered separately.				
	German	AWB823-1291-D 088930		1 off
	English	AWB823-1291-GB 088931		

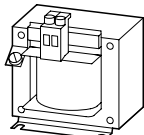
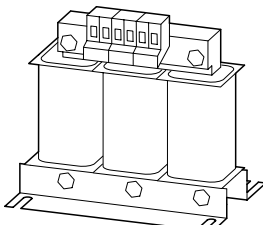
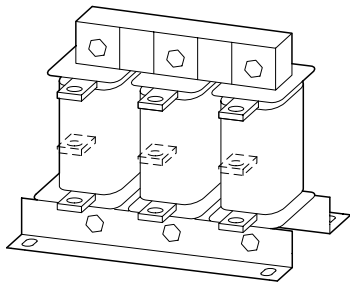

Moeller HPL0211-2004/2005

	Inductance	Rated current	Max. heat dissipation	Type	Std. pack	Notes
	L	I	P_v	Article no.		
	mH	A	W	Price See Price List		
Single-phase mains chokes						
• Max. permissible supply voltage 260 V + 0 %						
	5.05	5.8	9	DEX-LN1-006 269490	1 off	Mains chokes reduce the harmonic currents by up to 30 % and extend the frequency inverters' lifespan.
	3.41	8.6	11	DEX-LN1-009 269495		
	2.25	13	12	DEX-LN1-013 269496		
	1.63	18	17	DEX-LN1-018 269497		
	1.22	24	20	DEX-LN1-024 269498		
Three-phase mains chokes						
• Max. permissible supply voltage 550 V + 0 %						
	7.51	3.9	17	DEX-LN3-004 269500	1 off	Mains chokes reduce the harmonic currents by up to 30 % and extend the frequency inverters' lifespan.
	4.9	6	19	DEX-LN3-006 269501		
	2.94	10	33	DEX-LN3-010 269502		
	1.84	16	44	DEX-LN3-016 269503		
	1.18	25	57	DEX-LN3-025 269504		
	0.46	40	59	DEX-LN3-040 269505		
	0.37	50	58	DEX-LN3-050 269506		
	0.31	60	60	DEX-LN3-060 269507		
	0.23	80	86	DEX-LN3-080 269508		
	0.18	100	101	DEX-LN3-100 269509		
	0.15	120	100	DEX-LN3-120 269510		
	0.11	160	140	DEX-LN3-160 269511		
	0.09	200	154	DEX-LN3-200 269512		
	0.07	250	155	DEX-LN3-250 269513		
0.06	300	169	DEX-LN3-300 269514			

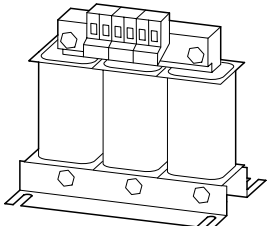
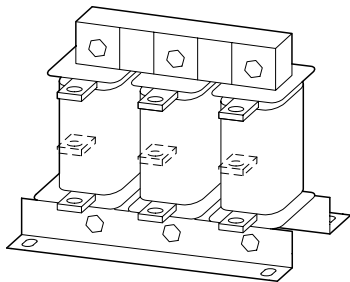

	Inductance	Rated current	Max. heat dissipation at 12 kHz	Type Article no.	Price See Price List	Std. pack	Notes
	<i>L</i> mH	<i>I</i> A	<i>P_v</i> W				
Motor chokes, three-phase							
• Max. permissible supply voltage 750 V + 0 %							
	2	5	24	DEX-LM3-005 269538		1 off	Motor chokes reduce the <i>dU/dt</i> value of the output voltage and therefore motor noise and heating. Motor chokes have larger dimension than mains chokes with the same rated current.
	4.1	8	54	DEX-LM3-008 269539			
	3	11	71	DEX-LM3-011 269541			
	1.5	16	78	DEX-LM3-016 269542			
	1	35	116	DEX-LM3-035 269543			
	0.6	50	168	DEX-LM3-050 269544			
	0.5	63	193	DEX-LM3-063 269545			
	0.5	80	206	DEX-LM3-080 269546			
	0.45	100	294	DEX-LM3-100 269547			
	0.35	150	424	DEX-LM3-150 269548			
	0.3	180	439	DEX-LM3-180 269549			
	0.2	220	517	DEX-LM3-220 269560			
0.15	260	520	DEX-LM3-260 269561				



DE4-BR1... braking resistors, potentiometers

Moeller HPL0211-2004/2005

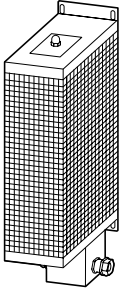
	Resistance	Rated braking power	Peak braking power	Type Article no.	Price See Price List	Std. pack	Notes
	R Ω	P_{DB} W	P_{Peak} W				
DE4-BR1... braking resistors							
	82	245	1700	DE4-BR1-082-245 219485		1 off	The braking resistors are designed for a load cycle of: <ul style="list-style-type: none"> • Max. 15 s braking at peak braking power • Min. 150 s recovery time after braking The resistors are built into a perforated sheet-metal enclosure and are fitted with an overtemperature protection switch (230 V, 1A, AC-1). Enclosure: galvanized perforated brass, open bottom. Degree of protection IP 20 is achieved only in installed state.
	100	200	1400	DE4-BR1-100-200 219489			
	200	100	700	DE4-BR1-200-100 219490			
	240	285	2000	DE4-BR1-240-285 219492			
	370	215	1500	DE4-BR1-370-215 219494			
	470	50	300	DE4-BR1-470-050 219495			
	470	140	1000	DE4-BR1-470-140 219497			

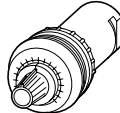
	Resistance	Rated power	Type Article no.	Price See Price List	Std. pack
	R k Ω	P W			
IP 66 potentiometers					
	1	$\cong 0.5$	M22-R1K 229489		1 off
	4.7	$\cong 0.5$	M22-R4K7 229490		
	10	$\cong 0.5$	M22-R10K 229491		



18/76 Selection data

DEX-LN... mains chokes, DEX-LM3... motor chokes

Moeller HPL0211-2004/2005

DF5, DF6 frequency inverters
DV5, DV6 vector frequency inverters

Type	Inductance	Rated current	Heat dissipation		Voltage drop		Connection		Bore	Pick-up
	L mH	I_e A	P_{VCU} W	u_k %			Terminal/connection lug			
					mm ²	AWG	mm	Nm		

Single-phase mains chokes, rated voltage 1 AC 230 V, 50 Hz

DEX-LN1-006	5.05	5.8	9	4	4	20 – 10	–	0.8
DEX-LN1-009	3.41	8.6	11	4	4	20 – 10	–	0.8
DEX-LN1-013	2.25	13	12	4	4	20 – 10	–	0.8
DEX-LN1-018	1.63	18	17	4	4	20 – 10	–	0.8
DEX-LN1-024	1.22	24	20	4	4	20 – 10	–	0.8

Three-phase mains chokes, rated voltage 3 AC 400 V, 50 Hz

DEX-LN3-004	7.51	3.9	17	4	4	20 – 10	–	0.8
DEX-LN3-006	4.9	6	19	4	4	20 – 10	–	0.8
DEX-LN3-010	2.94	10	33	4	4	20 – 10	–	0.8
DEX-LN3-016	1.84	16	44	4	4	20 – 10	–	0.8
DEX-LN3-025	1.18	25	57	4	4	20 – 10	–	0.8
DEX-LN3-040	0.64	40	59	2.5	10	20 – 6	–	1.5
DEX-LN3-050	0.37	50	58	2.5	Cu 15 × 2		7	3
DEX-LN3-060	0.31	60	60	2.5	Cu 15 × 2		7	3
DEX-LN3-080	0.23	80	86	2.5	Cu 20 × 3		9	6
DEX-LN3-100	0.186	100	101	2.5	Cu 20 × 3		9	6
DEX-LN3-120	0.15	120	100	2.5	Cu 25 × 5		11	10
DEX-LN3-160	0.11	160	140	2.5	Cu 25 × 5		11	10
DEX-LN3-200	0.09	200	154	2.5	Cu 25 × 5		11	10
DEX-LN3-250	0.07	250	155	2.5	Cu 40 × 5		14	15.5
DEX-LN3-300	0.06	300	169	2.5	Cu 40 × 5		14	15.5

Type	Inductance	Rated current	Heat dissipation (clock frequency)			Connection		Bore	Pick-up
	L mH	I_e A	P_{VCU} (3 kHz) W	P_{VCU} (5 kHz) W	P_{VCU} (12 kHz) W	Terminal/connection lug			
						mm ²	AWG	mm	Nm

Three-phase motor chokes, rated voltage 3 AC 400 V, max. 200 Hz

DEX-LM3-005	2	5	12	14	24	4	20 – 10	–	0.8
DEX-LM3-008	4.1	8	32	46	54	4	20 – 10	–	0.8
DEX-LM3-011	3	11	45	66	71	4	20 – 10	–	0.8
DEX-LM3-016	1.5	16	50	75	78	4	20 – 10	–	0.8
DEX-LM3-035	1	35	75	114	116	4	20 – 10	–	0.8
DEX-LM3-050	0.6	50	110	157	168	10	20 – 6	–	1.5
DEX-LM3-063	0.5	63	130	190	193	Cu 15 × 2		7	3
DEX-LM3-080	0.5	80	132	206	206	Cu 20 × 3		9	6
DEX-LM3-100	0.45	100	177	279	294	Cu 20 × 3		9	6
DEX-LM3-150	0.35	150	293	418	424	Cu 25 × 5		11	10
DEX-LM3-180	0.3	180	418	298	439	Cu 25 × 5		11	10
DEX-LM3-220	0.2	220	344	512	517	Cu 40 × 5		14	15.5
DEX-LM3-260	0.15	260	358	526	520	Cu 40 × 5		14	15.5



Moeller HPL0211-2004/2005

			DEX-LN-1... mains chokes	DEX-LN-3... mains chokes	DEX-LM-3... motor chokes
General					
Standards			IEC/EN 61558-2-20-2000, VDE 0570 Part 2-20/04-2001		
Operating temperature	°C		-25 to +40, up to 70 with current derating (see the note)		
Storage temperature	°C		-25 – +85	-25 – +85	-25 – +85
Mechanical shock resistance			11 ms ² /15 g, 3 impacts	11 ms ² /15 g, 3 impacts	11 ms ² /15 g, 3 impacts
Vibration resistance	g		1 (at 0 – 150 Hz)	1 (at 0 – 150 Hz)	1 (at 0 – 150 Hz)
Vibration			0.35 mm at 10 – 55 Hz	0.35 mm at 10 – 55 Hz	0.35 mm at 10 – 55 Hz
Pollution degree			1 (VDE 0160)	1 (VDE 0160)	1 (VDE 0160)
Altitude	m		0 to 1000 above sea level, up to 5000 with current derating (see notes)		
Mounting position			Standing vertically, suspended horizontally		
Free surrounding areas			< 50	< 50	< 50
Degree of protection (terminals)			IP 20	IP 20 up to 40 A IP 20 from 50 A	IP 20 up to 50 A IP 20 from 63 A
Rated duty factor	% DF		100	100	100
Overload cycle			1.5 × I _e for 60 s every 600 s	1.5 × I _e for 60 s every 600 s	1.5 × I _e for 60 s every 600 s (< 24 A) 1.2 × I _e for 60 s every 600 s (> 24 A)
Weight	kg		0.7	1.5	1.5
Electrical data					
Rated voltage	U_e	V AC	230	400	400
Max. supply voltage	U_L	V AC	260 ± 0 %	550 ± 0 %	750 ± 0 %
Operating frequency	f	Hz	50/60	50/60	0 to 200
Insulation class			B	B	B (100 A) F (150 A)
Electrical connection					
Terminations			●	● (40 A)	● (50 A)
Connection lugs			●	● (50 A)	● (63 A)
PE stud			●	●	●

Notes

The following applies for the installation altitude: Derating with respect to the rated current I_e.

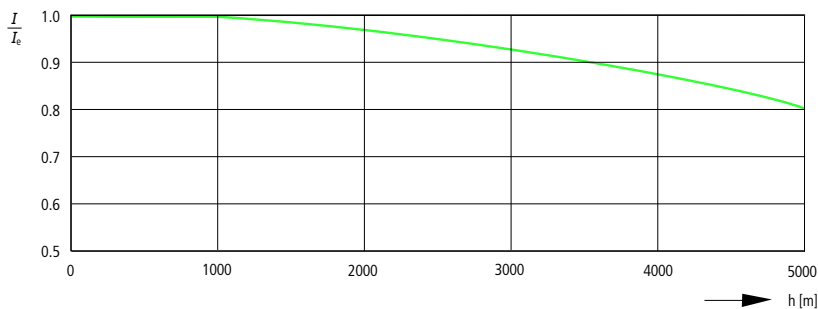

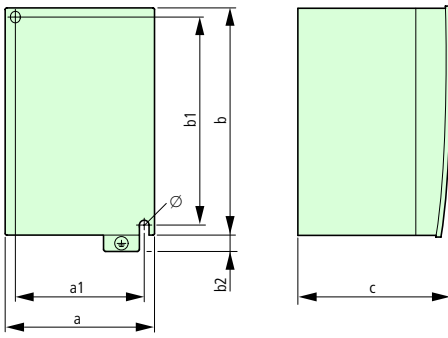

Type	a	a1	b	b1	b2	c	∅
DF5-322-018	88.5	67	126	110	7	117	5
DF5-322-037	88.5	67	126	110	7	117	5
DV5-322-018	88.5	67	136	110	7	103	5
DV5-322-037	88.5	67	136	110	7	117	5
DV5-322-055	88.5	67	136	110	7	117	5

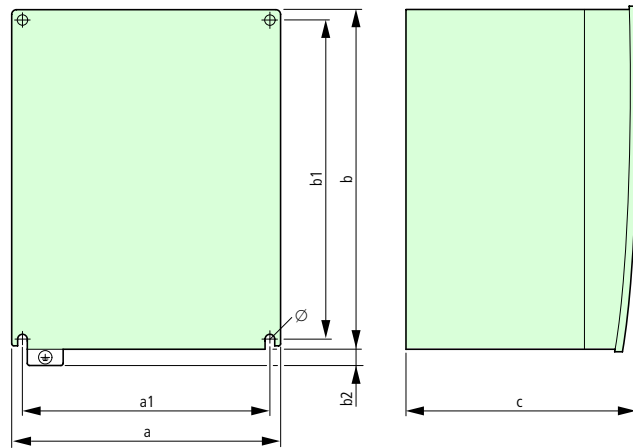

Type	a	a1	b	b1	b2	c	∅
DF5-322-055	118	98	136	118	7	140	5
DF5-322-075	118	98	136	118	7	140	5
DF5-322-1K1	140	128	184.5	168	7	164	5
DF5-322-1K5	140	128	184.5	168	7	164	5
DF5-322-2K2	140	128	184.5	168	—	175	5
DF5-340-037	118	98	136	118	7	140	5
DF5-340-075	118	98	136	118	—	167	5
DF5-340-1K5	118	98	136	118	—	167	5
DF5-340-2K2	140	128	184.5	168	—	175	5
DF5-340-3K0	140	128	184.5	168	—	175	5
DF5-340-4K0	140	128	184.5	168	—	175	5
DF5-340-5K5	182	160	260	236	13	177	7
DF5-340-7K5	182	160	260	236	13	177	7
DV5-322-075	118	98	136	118	7	140	5
DV5-322-1K1	118	98	136	118	7	140	5
DV5-322-1K5	140	128	184.5	168	7	164	5
DV5-322-2K2	140	128	184.5	168	—	175	5
DV5-340-037	118	98	136	118	7	140	5
DV5-340-075	118	98	136	118	—	167	5
DV5-340-1K5	118	98	136	118	—	167	5
DV5-340-2K2	118	98	136	118	—	167	5
DV5-340-3K0	140	128	184.5	168	—	175	5
DV5-340-4K0	140	128	184.5	168	—	175	5
DV5-340-5K5	182	160	260	236	13	177	7
DV5-340-7K5	182	160	260	236	13	177	7

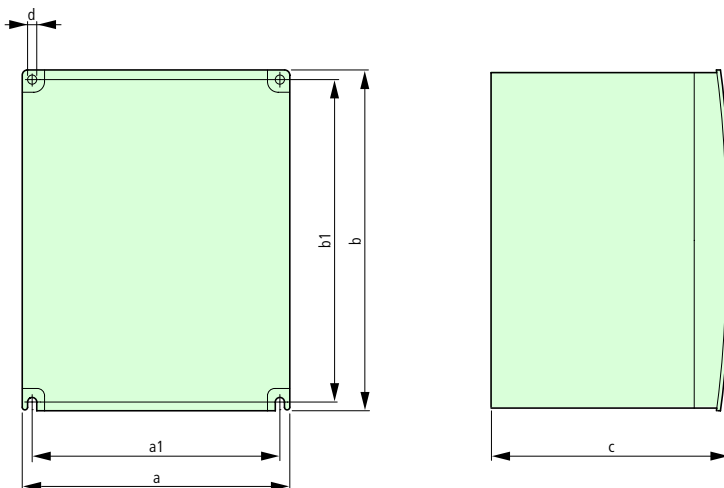

Type	a	a1	b	b1	c	d
DF6-340-11K	216	189	266	246	190.5	7
DF6-340-15K	216	189	266	246	190.5	7
DF6-340-18K5	256	229	396	376	210.5	7
DF6-340-22K	256	229	396	376	210.5	7
DF6-340-30K	256	229	396	376	210.5	7
DF6-340-37K	316	265	546	510	215.5	10
DF6-340-45K	396	300	556	520	270.5	10
DF6-340-55K	396	300	556	520	270.5	10
DF6-340-75K	396	300	556	520	270.5	10
DF6-340-90K	396	300	706	670	290.5	12
DF6-340-110K	396	300	706	670	290.5	12
DF6-340-132K	486	380	746	730	282	12
DV6-340-075	159	130	260.5	241	152	6
DV6-340-1K5	159	130	260.5	241	152	6
DV6-340-2K2	159	130	260.5	241	152	6
DV6-340-4K0	159	130	260.5	241	152	6
DV6-340-5K5	159	130	260.5	241	152	6
DV6-340-7K5	216	189	266	246	190.5	7
DV6-340-11K	216	189	266	246	190.5	7
DV6-340-15K	256	229	396	376	210.5	7
DV6-340-18K5	256	229	396	376	210.5	7
DV6-340-22K	256	229	396	376	210.5	7
DV6-340-30K	310	265	540	510	202	10
DV6-340-37K	390	300	550	520	255.5	10
DV6-340-45K	390	300	550	520	255.5	10
DV6-340-55K	390	300	550	520	255.5	10
DV6-340-75K	390	300	700	670	275.5	12
DV6-340-90K	390	300	700	670	275.5	12
DV6-340-110K	480	380	740	710	293.2	12
DV6-340-132K	480	380	740	710	293.2	12



Moeller HPL0211-2004/2005

DE5-LZ1-007-V2
DE5-LZ1-012-V2
DE5-LZ1-024-V2

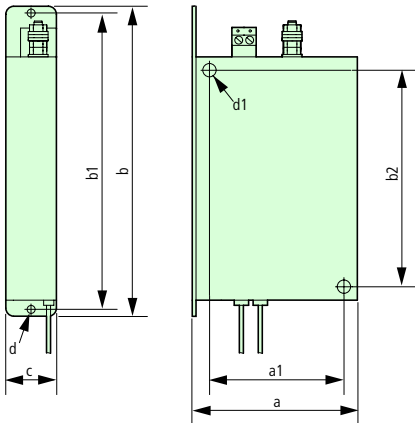

Type	a	a1	b	b1	b2	c	d	d1
DE5-LZ1-007-V2	80	67	155	145	110	27	5	2 × 6
DE5-LZ1-012-V2	110	98	165	155	118	27	5	4 × 6
DE5-LZ1-024-V2	140	128	215	205	168	29	5	4 × 6

DE5-LZ3-007-V4
DE5-LZ3-011-V4
DE5-LZ3-020-V4

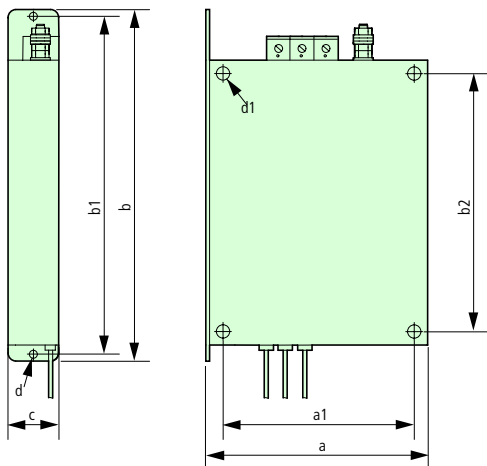

Type	a	a1	b	b1	b2	c	d	d1
DE5-LZ3-007-V4	110	98	160	150	118	27	5	4 × 6
DE5-LZ3-011-V4	140	128	210	200	168	31	5	4 × 6
DE5-LZ3-020-V4	182	160	287	277	236	35	5	4 × 7



18/80 Dimensions

DE6-... radio interference filters

Moeller HPL0211-2004/2005

DF5, DF6 frequency inverters
DV5, DV6 vector frequency inverters

DE6-LZ3-013-V4
DE6-LZ3-032-V4
DE6-LZ3-064-V4

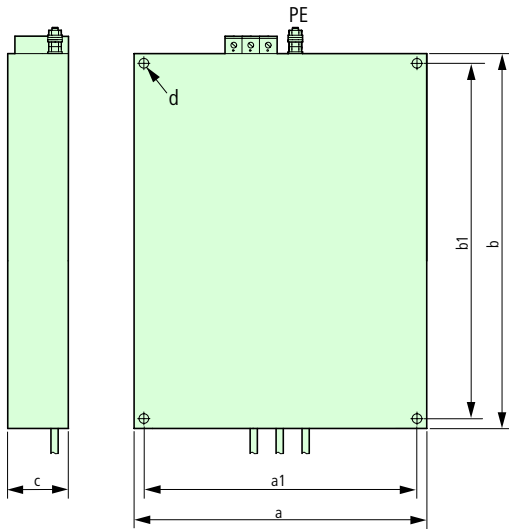

Type	a	a1	b	b1	c	d
DE6-LZ3-013-V4	143	130	255	241	29	4 × 6
DE6-LZ3-032-V4	203	189	260	246	43	4 × 7
DE6-LZ3-064-V4	244	229	390	376	45	4 × 7

DE6-LZ3-080-V4
DE6-LZ3-115-V4
DE6-LZ3-125-V4
DE6-LZ3-150-V4
DE6-LZ3-220-V4
DE6-LZ3-260-V4

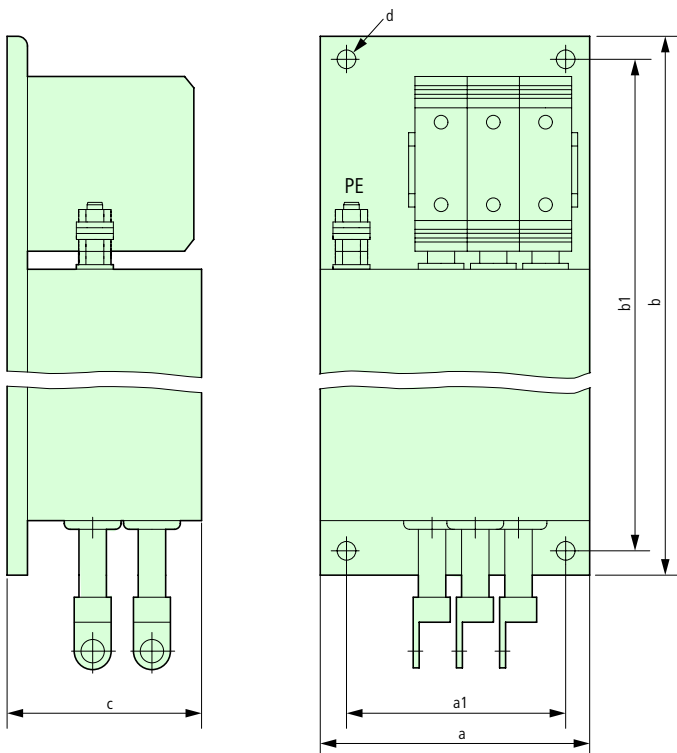

Type	a	a1	b	b1	c	d	PE
DE6-LZ3-080-V4	60	40	400	380	87	4 × 8.5	M8 × 24
DE6-LZ3-115-V4	70	50	440	420	110	4 × 8.5	M10 × 34
DE6-LZ3-125-V4	70	50	440	420	110	4 × 8.5	M10 × 34
DE6-LZ3-150-V4	130	105	525	505	94	4 × 9	M10 × 34
DE6-LZ3-220-V4	130	105	525	505	94	4 × 9	M10 × 34
DE6-LZ3-260-V4	142	120	620	600	116	4 × 9	M12 × 48



Moeller HPL0211-2004/2005

DEX-LN1-006...024

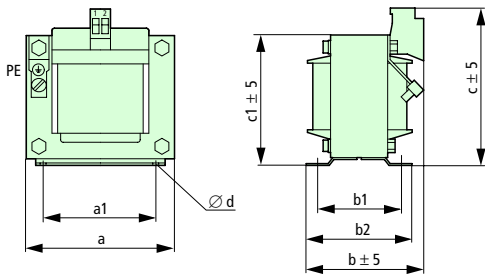

Type	a	a1	b	b1	b2	c	c1	d	Weight [kg]
DEX-LN1-006	66	50	71	44	55	80	61	4.5 × 8	0.7
DEX-LN1-009	66	50	71	44	55	80	61	4.5 × 8	0.7
DEX-LN1-013	84	64	67	47	60	90	75	4.8 × 8	1.5
DEX-LN1-018	84	64	90	70	83	90	75	4.8 × 8	1.5
DEX-LN1-024	84	64	67	47	60	90	75	4.8 × 8	2

DEX-LN3-004...040

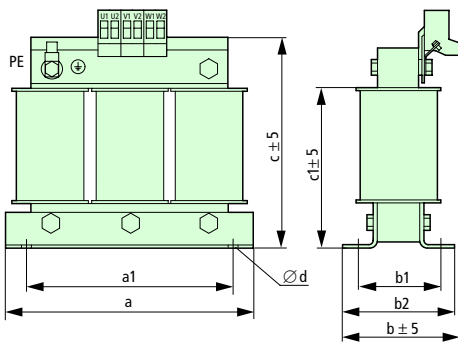

Type	a	a1	b	b1	b2	c	c1	d	Weight [kg]
DEX-LN3-004	115	100	66	50	66	118	84	5 × 10	1.5
DEX-LN3-006	115	100	66	50	66	118	84	5 × 10	1.5
DEX-LN3-010	140	125	61	50	61	138	105	5 × 10	2.2
DEX-LN3-016	140	125	71	50	71	138	105	5 × 10	2.9
DEX-LN3-025	195	175	104	50	76.5	175	134	8 × 13	4.8
DEX-LN3-040	195	175	104	50	76.5	188	134	8 × 13	4.8

DEX-LN3-050...300

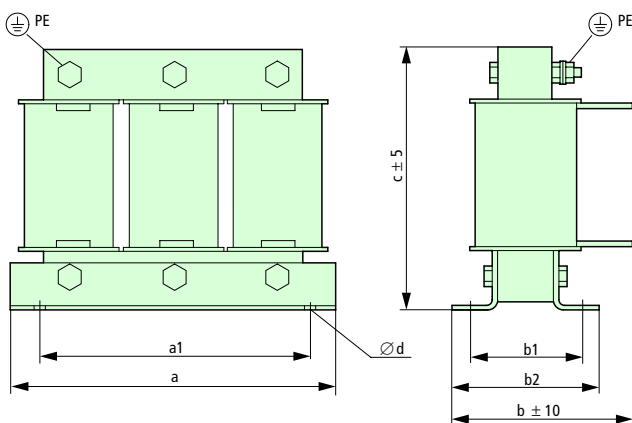

Type	a	a1	b	b1	b2	c	d	Weight [kg]
DEX-LN3-050	195	175	105	75	91.5	132	8 × 13	5.9
DEX-LN3-060	195	175	105	75	91.5	132	8 × 13	5.9
DEX-LN3-080	220	200	110	50	81.5	160	8 × 13	7.3
DEX-LN3-100	220	200	130	75	101.5	160	8 × 13	10.2
DEX-LN3-120	220	200	130	75	101.5	160	8 × 13	10.2
DEX-LN3-160	270	250	125	75	96	200	8 × 13	12.3
DEX-LN3-200	270	250	155	100	120	202	8 × 13	14.9
DEX-LN3-250	270	250	155	100	125	210	10 × 18	20.6
DEX-LN3-300	270	250	155	100	125	210	10 × 18	20.6

Notes

The position of connection lugs U2-V2-W2 depends on the coil material and can deviate from the position illustrated here.



DEX-LM3-005...050

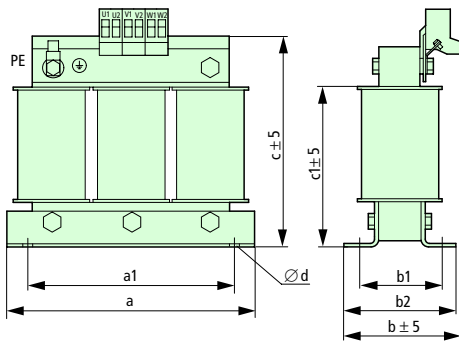

Type	a	a1	b	b1	b2	c	c1	d	Weight [kg]
DEX-LM3-005	115	100	66	50	66	118	84	5 × 10	1.5
DEX-LM3-008	195	175	104	50	76.5	175	134	8 × 13	4.8
DEX-LM3-011	195	175	104	50	76.5	175	134	8 × 13	4.8
DEX-LM3-016	195	175	104	50	76.5	175	134	8 × 13	4.8
DEX-LM3-035	220	200	132	75	101.5	195	160	8 × 13	7.3
DEX-LM3-050	270	250	106	75	96	228	198	8 × 13	12.3

DEX-LM3-063...300

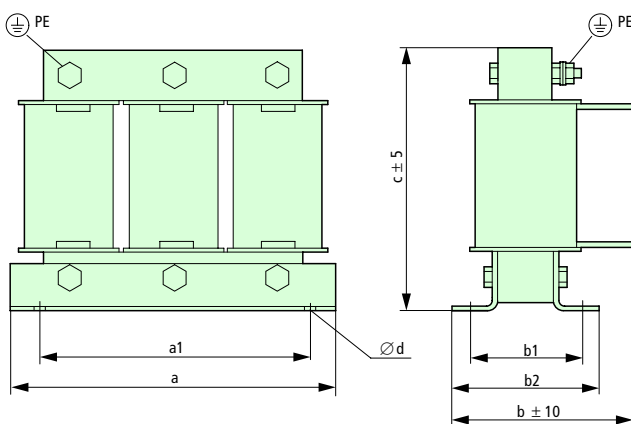

Type	a	a1	b	b1	b2	c ¹⁾ ±10	d	Weight [kg]
DEX-LM3-063	270	250	155	100	120	202	8 × 13	14.9
DEX-LM3-080	270	250	155	100	125	210	10 × 18	20.6

Type	a	a1	b	b1	b2	c ¹⁾ ±30	d	Weight [kg]
DEX-LM3-100	384	350	215	100	130	258	12 × 20	31
DEX-LM3-150	384	350	260	150	180	258	12 × 20	45
DEX-LM3-180	384	350	260	150	180	258	12 × 20	45
DEX-LM3-220	384	350	260	150	180	258	12 × 20	45
DEX-LM3-260	384	350	260	150	180	258	12 × 20	45

Notes

¹⁾ Tolerance depending on air gap.

The position of connection lugs U2-V2-W2 depends on the coil material and can deviate from the position illustrated here.

Braking units

DE4-BM

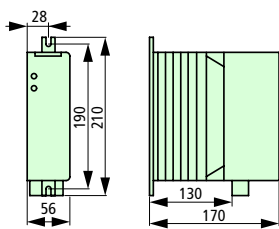

DE4-BU

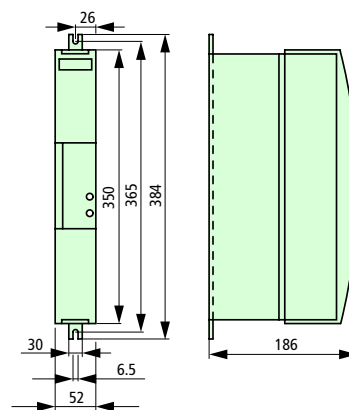

Type	Ø	Weight [kg]
DE4-BM2-1	M6	1.3
DE4-BM4-1	M6	1.3
DE4-BU4-1	M6	1.2

Notes

Ø: Dimension for fixing screws



Moeller HPL0211-2004/2005

Braking resistors

DE4-BR1-...

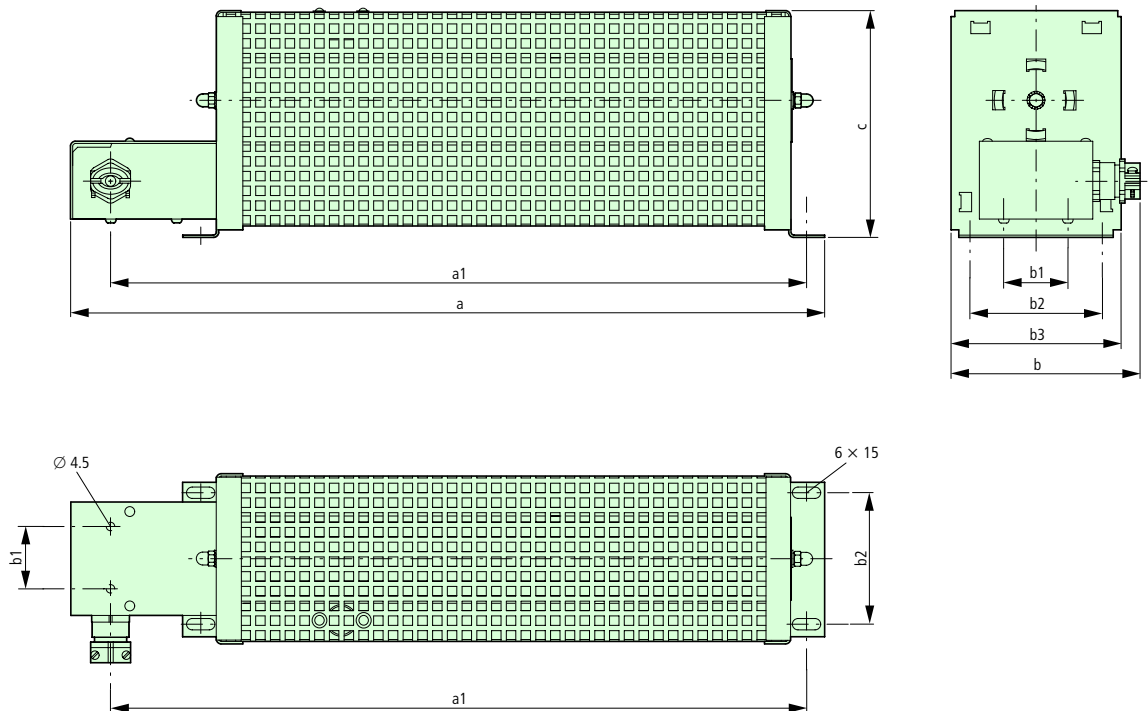

Type	a	a1	b	b1	b2	b3	c	Weight [kg]
DE4-BR1-470-050	200	170	80	35	40	60	90	1.2
DE4-BR1-200-100	300	270	80	35	40	60	90	1.3
DE4-BR1-470-140	300	270	80	35	40	60	90	1.3
DE4-BR1-240-285	400	370	95	35	70	90	95	1.8
DE4-BR1-082-245	430	400	95	35	70	90	95	1.7
DE4-BR1-100-200	430	400	95	35	70	90	95	1.7
DE4-BR1-370-215	430	400	95	35	70	90	95	1.7

Potentiometers

M22-..K..

