

Inverter

MICROMASTER 420



- 2/2 Description
- 2/4 Circuit diagrams
- 2/6 Technical data
- 2/8 Selection and ordering data
- 2/9 Options
- 2/17 Dimension drawings

MICROMASTER 420

Description



Applications

The MICROMASTER 420 inverter is suitable for a variety of variable-speed drive applications. It is especially suitable for applications with pumps, fans and in conveyor systems.

It is the ideal cost-optimized frequency inverter solution. The inverter is especially characterized by its customer-oriented performance and ease-of-use. Its large mains voltage range enables it to be used all over the world.

Design

The MICROMASTER 420 inverter has a modular design. The operator panels and communication modules can be easily exchanged without requiring any tools.

Main characteristics

- Easy, guided start-up
- Modular construction allows maximum configuration flexibility
- Three fully programmable isolated digital inputs
- One analog input (0 V to 10 V, scaleable) or for use as 4th digital input
- One programmable analog output (0 mA to 20 mA)
- One programmable relay output (30 V DC/5 A resistive load; 250 V AC/2A inductive load)
- Low-noise motor operation through high pulse frequency, adjustable (observe derating if necessary)
- Complete protection for motor and inverter.

Options (overview)

- EMC filter, Class A/B
- LC filter
- Line commutating chokes
- Output chokes
- Gland plates
- Basic Operator Panel (BOP) for parameterizing the inverter
- Advanced Operator Panel (AOP) with multi-language plain text display
- Asian Advanced Operator Panel (AAOP) with Chinese and English plain text display
- Communication modules
 - PROFIBUS
 - DeviceNet
 - CANopen
- PC connection kits
- Mounting kits for installing the operator panels in the control cabinet doors
- PC start-up programs executable under Windows 95/98 and NT/2000/XP Professional
- TIA integration with Drive ES

International standards

- The MICROMASTER 420 inverter complies with the requirements of the EU low-voltage guideline
- The MICROMASTER 420 inverter has the **CE** marking
- acc. to **UL** and **cUL** certified
- c-tick **C**

Note:

See Appendix for standards.

Mechanical features

- Modular design
- Operating temperature
-10 °C to +50 °C
(+14 °F to +122 °F)
- Compact housing as a result of high power density
- Easy cable connection, mains and motor connections are separated for optimum electromagnetic compatibility
- Detachable operator panels
- Screwless control terminals

Performance features

- Latest IGBT technology
- Digital microprocessor control
- Flux Current Control (FCC) for improved dynamic response and optimized motor control
- Linear V/f characteristic
- Quadratic V/f characteristic
- Multipoint characteristic (programmable V/f characteristic)
- Flying restart
- Slip compensation
- Automatic restart following mains failure or fault
- Internal PI controller for simple process control
- Programmable acceleration/deceleration times from 0 s to 650 s
- Ramp smoothing
- Fast Current Limit (FCL) for trip-free operation
- Fast, repeatable digital input response time
- Fine adjustment using a high-resolution 10-bit analog input
- Compound braking for controlled rapid braking
- Four skip frequencies
- Removable "Y" capacitor for use on IT systems (with non-grounded mains supplies, the "Y" capacitor must be removed and an output choke installed).

Protection features

- Overload current 1.5 x rated output current (i.e. 150 % overload capability) for 60 s, cycle time 300 s
- Overvoltage/undervoltage protection
- Inverter overtemperature protection
- Motor protection using PTC via digital input (possible with supplementary circuit)
- Earth fault protection
- Short-circuit protection
- I^2t motor thermal protection
- Locked motor protection
- Stall prevention
- Parameter interlock

MICROMASTER 420

Circuit diagrams

General circuit diagram

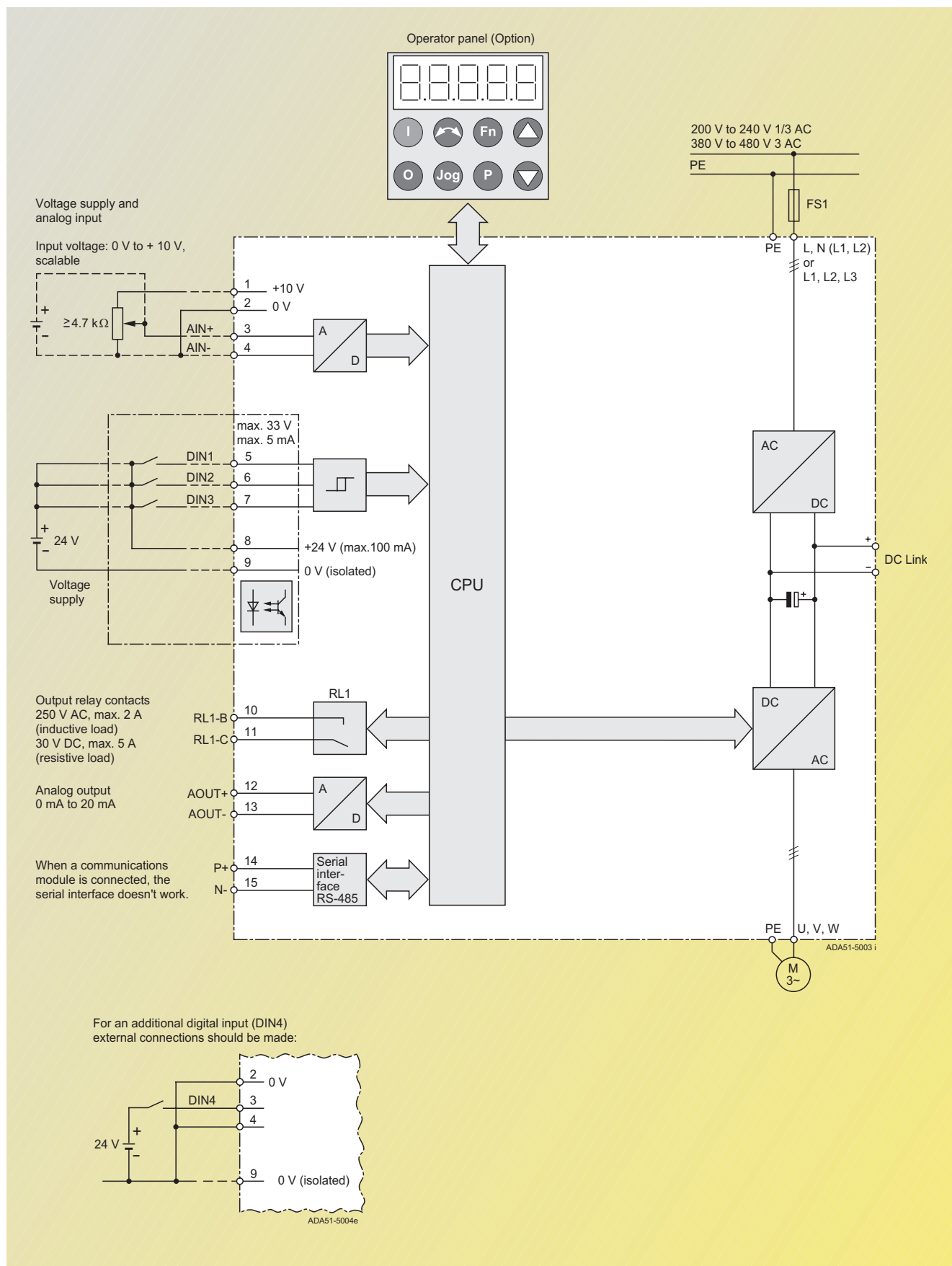

Terminal connection diagram

Example frame size A

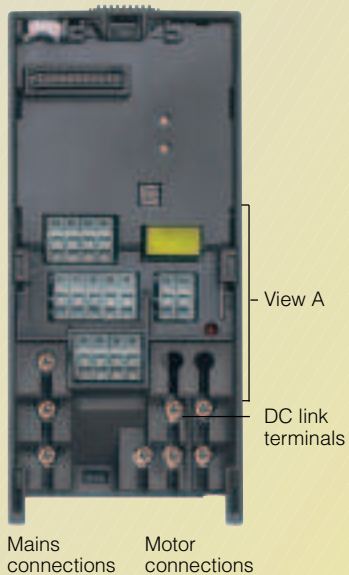

View A

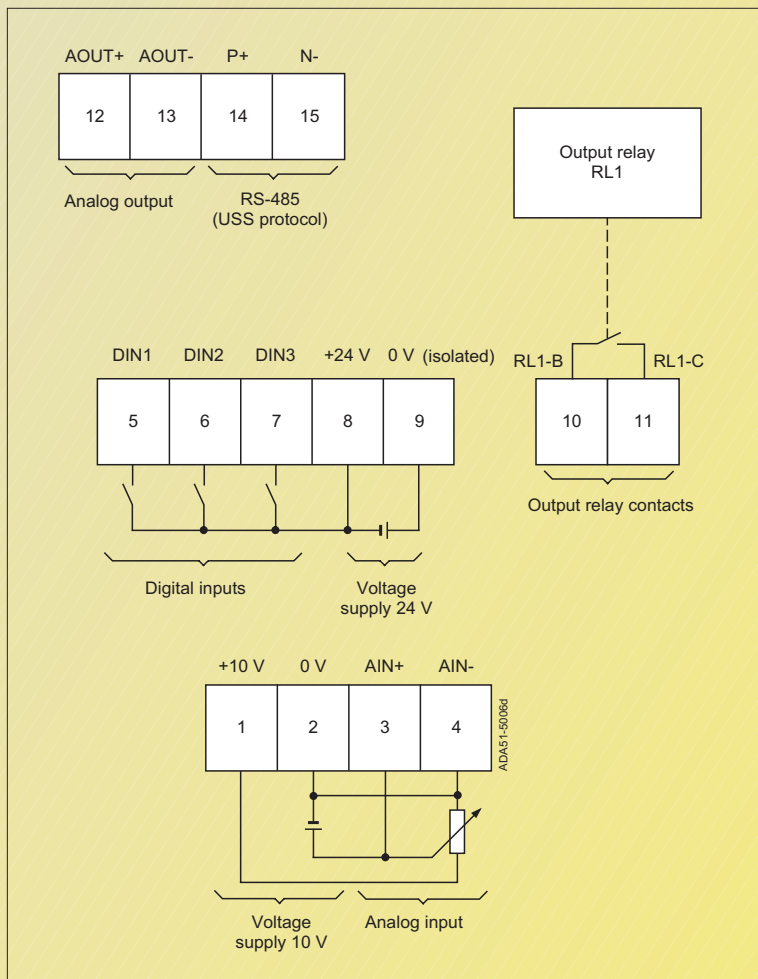

MICROMASTER 420

Technical data

MICROMASTER 420 inverter

Mains voltage and power ranges	1 AC 200 V to 240 V \pm 10 % 3 AC 200 V to 240 V \pm 10 % 3 AC 380 V to 480 V \pm 10 %	0.12 kW to 3 kW 0.12 kW to 5.5 kW 0.37 kW to 11 kW	
Power frequency	47 Hz to 63 Hz		
Output frequency	0 Hz to 650 Hz		
Power factor	\geq 0.95		
Inverter efficiency	96 % to 97 %		
Overload capability	Overload current 1.5 x rated output current (i.e. 150 % overload capability) for 60 s, cycle time 300 s		
Inrush current	Less than rated input current		
Control method	Linear V/f-characteristic; quadratic V/f characteristic; multipoint characteristic (programmable V/f characteristic); flux current control (FCC)		
Pulse frequency	16 kHz (standard with 1/3 AC 230 V) 4 kHz (standard with 3 AC 400 V) 2 kHz to 16 kHz (in 2 kHz steps)		
Fixed frequencies	7, programmable		
Skip frequency ranges	4, programmable		
Setpoint resolution	0.01 Hz digital 0.01 Hz serial 10 bit analog		
Digital inputs	3 fully programmable isolated digital inputs; switchable PNP/NPN		
Analog input	1, for setpoint or PI controller (0 V to 10 V, scaleable or for use as 4th digital input)		
Relay outputs	1, programmable, 30 V DC/5 A (resistive load); 250 V AC/2A (inductive load)		
Analog output	1, programmable (0 mA to 20 mA)		
Serial interfaces	RS-485, optional RS-232		
Motor cable lengths	without output choke max. 50 m (shielded) max. 100 m (unshielded) without output choke (see variant dependent options)		
Electromagnetic compatibility	Inverter available with internal EMC filter Class A; available as options are EMC filters to EN 55 011, Class A or Class B		
Braking	DC braking, compound braking		
Degree of protection	IP20		
Operating temperature	-10 °C to +50 °C (+14 °F to +122 °F)		
Storage temperature	-40 °C to +70 °C (-40 °F to +158 °F)		
Relative humidity	95 % (non-condensing)		
Site altitude	Up to 1000 m above sea level without derating		
Protection features for	<ul style="list-style-type: none"> • Undervoltage • Overvoltage • Overload • Earth faults • Short circuit • Stall prevention • Locked motor protection • Motor overtemperature • Inverter overtemperature • Parameter interlock 		
Compliance with standards	®, c®®, CE, c-tick		
CE marking	Conformity with low-voltage directive 73/23/EEC		
Dimensions and weights (without options)	Frame size (FS)	H x W x D (mm)	Weight, approx. (kg)
	A	173 x 73 x 149	1.0
	B	202 x 149 x 172	3.3
	C	245 x 185 x 195	5.0

Derating data

PWM frequency

Output (for 3 AC 400 V) kW	Rated output current in A for a pulse frequency of						
	4 kHz	6 kHz	8 kHz	10 kHz	12 kHz	14 kHz	16 kHz
0.37	1.2	1.2	1.2	1.2	1.2	1.2	1.1
0.55	1.6	1.6	1.6	1.6	1.6	1.6	1.1
0.75	2.1	2.1	2.1	2.1	1.6	1.6	1.1
1.1	3.0	3.0	2.7	2.7	1.6	1.6	1.1
1.5	4.0	4.0	2.7	2.7	1.6	1.6	1.1
2.2	5.9	5.9	5.1	5.1	3.6	3.6	2.6
3.0	7.7	7.7	5.1	5.1	3.6	3.6	2.6
4.0	10.2	10.2	6.7	6.7	4.8	4.8	3.6
5.5	13.2	13.2	13.2	13.2	9.6	9.6	7.5
7.5	18.4	18.4	13.2	13.2	9.6	9.6	7.5
11	26.0	26.0	17.9	17.9	13.5	13.5	10.4

Operating temperature

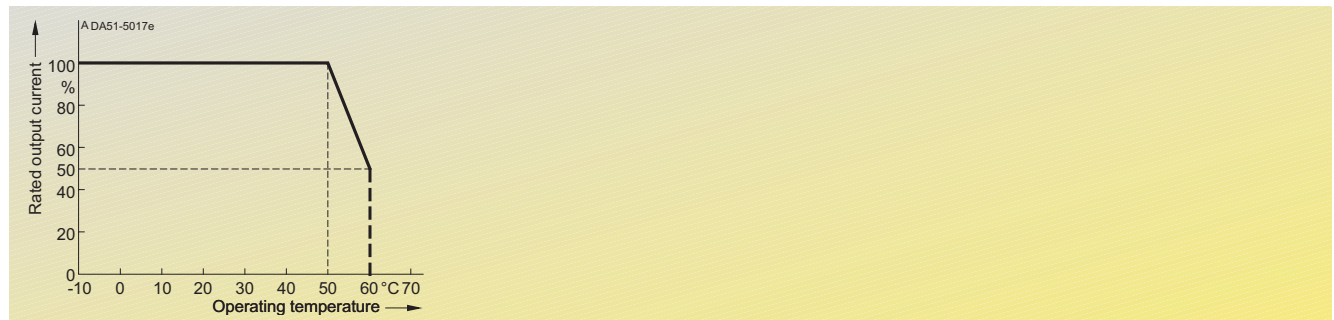

Installation height above sea level

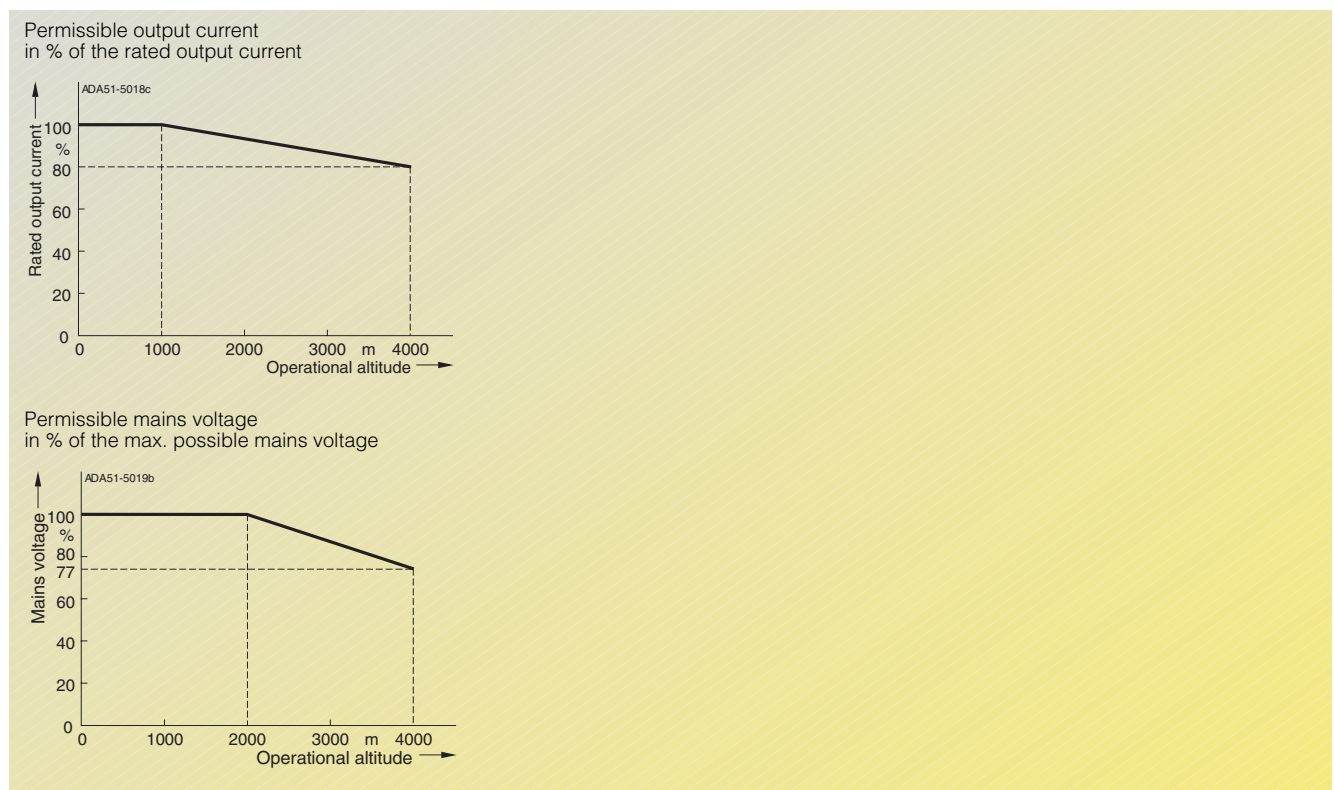

MICROMASTER 420

Selection and ordering data

MICROMASTER 420 inverter

Output		Rated input current ¹⁾	Rated output current	Frame size	Order No.	
kW	hp	A	A	(FS)	MICROMASTER 420 without filter ³⁾	MICROMASTER 420 with internal filter Class A ²⁾
Mains operating voltage 1 AC 200 V to 240 V						
0.12	0.16	2.3	0.9	A	6SE6420-2UC11-2AA1	6SE6420-2AB11-2AA1
0.25	0.33	4.3	1.7	A	6SE6420-2UC12-5AA1	6SE6420-2AB12-5AA1
0.37	0.50	5.9	2.3	A	6SE6420-2UC13-7AA1	6SE6420-2AB13-7AA1
0.55	0.75	7.7	3.0	A	6SE6420-2UC15-5AA1	6SE6420-2AB15-5AA1
0.75	1.0	10.1	3.9	A	6SE6420-2UC17-5AA1	6SE6420-2AB17-5AA1
1.1	1.5	15.0	5.5	B	6SE6420-2UC21-1BA1	6SE6420-2AB21-1BA1
1.5	2.0	18.6	7.4	B	6SE6420-2UC21-5BA1	6SE6420-2AB21-5BA1
2.2	3.0	26.8	10.4	B	6SE6420-2UC22-2BA1	6SE6420-2AB22-2BA1
3.0	4.0	35.9	13.6	C	6SE6420-2UC23-0CA1	6SE6420-2AB23-0CA1
Mains operating voltage 3 AC 200 V to 240 V						
0.12	0.16	1.1	0.9	A	6SE6420-2UC11-2AA1	–
0.25	0.33	2.2	1.7	A	6SE6420-2UC12-5AA1	–
0.37	0.50	3.0	2.3	A	6SE6420-2UC13-7AA1	–
0.55	0.75	3.9	3.0	A	6SE6420-2UC15-5AA1	–
0.75	1.0	5.2	3.9	A	6SE6420-2UC17-5AA1	–
1.1	1.5	7.6	5.5	B	6SE6420-2UC21-1BA1	–
1.5	2.0	10.2	7.4	B	6SE6420-2UC21-5BA1	–
2.2	3.0	14.1	10.4	B	6SE6420-2UC22-2BA1	–
3.0	4.0	18.4	13.6	C	6SE6420-2UC23-0CA1	6SE6420-2AC23-0CA1
4.0	5.0	23.3	17.5	C	6SE6420-2UC24-0CA1	6SE6420-2AC24-0CA1
5.5	7.5	28.0	22.0	C	6SE6420-2UC25-5CA1	6SE6420-2AC25-5CA1
Mains operating voltage 3 AC 380 V to 480 V						
0.37	0.50	1.5	1.2	A	6SE6420-2UD13-7AA1	–
0.55	0.75	1.9	1.6	A	6SE6420-2UD15-5AA1	–
0.75	1.0	2.4	2.1	A	6SE6420-2UD17-5AA1	–
1.1	1.5	3.7	3.0	A	6SE6420-2UD21-1AA1	–
1.5	2.0	4.8	4.0	A	6SE6420-2UD21-5AA1	–
2.2	3.0	6.5	5.9	B	6SE6420-2UD22-2BA1	6SE6420-2AD22-2BA1
3.0	4.0	8.6	7.7	B	6SE6420-2UD23-0BA1	6SE6420-2AD23-0BA1
4.0	5.0	11.6	10.2	B	6SE6420-2UD24-0BA1	6SE6420-2AD24-0BA1
5.5	7.5	15.6	13.2	C	6SE6420-2UD25-5CA1	6SE6420-2AD25-5CA1
7.5	10.0	22.0	19.0	C	6SE6420-2UD27-5CA1	6SE6420-2AD27-5CA1
11	15.0	32.3	26.0	C	6SE6420-2UD31-1CA1	6SE6420-2AD31-1CA1



See Appendix for note on ordering.

All MICROMASTER 420 inverters are supplied with a Status Display Panel (SDP). A BOP, AOP or other options have to be ordered separately (see Pages 2/11 to 2/15).

Motors for MICROMASTER 420

Catalog M 11 contains selection and ordering data for motors which are particularly suitable for operation with the MICROMASTER 420 inverters (see Appendix for overview).

This catalog is suitable for IEC motors. For motors according to US standards (NEMA) please refer to: <http://www.sea.siemens.com/motors>

1) Supplementary conditions: Input current at rated operating point, applicable at short-circuit voltage of the supply $U_{sc} = 1\%$ with reference to the inverter rated power and rated mains voltage of 240 V or 400 V

without a line commutating choke. If a line commutating choke is used, the specified values at 200 V to 240 V are reduced to between 55% and 70% and 380 V – 480 V to between 70% and 80%.

2) Use of MICROMASTER inverters with internal filter is not permissible on non-grounded (IT) mains supplies.

3) Generally suited to heavy industrial applications. For details please refer to Appendix on page A/4.

Overview

EMC filter, Class A

Filter for inverters without an internal filter for

- 3 AC 200 V to 240 V, frame sizes A and B
- 3 AC 380 V to 480 V, frame size A.

All other inverters can be supplied with an internal Class A filter.

The requirements are fulfilled using shielded cables with a max. length of 25 m.

EMC filter, Class B

Filter for inverters without an internal filter for

- 3 AC 200 V to 240 V, frame sizes A and B
- 3 AC 380 V to 480 V, frame size A.

With this filter, the inverter complies with the emission standard EN 55 011, Class B.

The requirements are fulfilled using shielded cables with a max. length of 25 m.

Additional EMC filter, Class B

Available for inverters with an internal Class A EMC filter.

With this filter, the inverter complies with the emission standard EN 55 011, Class B.

The requirements are fulfilled using shielded cables with a max. length of 25 m.

Filter Class B with low leakage currents

EMC filter for 1 AC 200 V to 240 V inverters, frame sizes A and B, without an internal EMC filter Class A.

With this filter, the inverter complies with the emission standard EN 55 011, Class B. The leakage currents are reduced to < 3.5 mA.

The requirements are fulfilled using shielded cables with a max. length of 5 m.

Leakage currents:

The leakage currents of the inverters with/without filter (internal/external) may exceed 30 mA. Typical values in practice are between 10 mA and 50 mA. The exact values depend on the design, environment and cable lengths. Interference-free operation with residual current operated devices with a trigger value of 30 mA cannot be guaranteed. However, operation with residual current circuit-breakers with a trigger value of 300 mA is possible. Please refer to the Instruction Manual for details.

LC filter

The LC filter limits the rate of rise of voltage and the capacitive charge/discharge currents which usually occur with inverter operation. This means that much longer shielded motor cables are possible when using LC filters and the service life of the motor achieves values similar to those with direct mains operation.

The LC filters can be used for all MICROMASTER 420 inverters of frame sizes A to C.

- Frame sizes A and B: A maximum of two footprint components plus inverter are permissible. The LC filter must be mounted as the lowest component.
- Frame size C: Only one footprint component is permissible for frame size C. If a line choke and LC filter are used, the line choke must be located on the left of the inverter. Required spacing: 75 mm.

Please note when using LC filters:

- Only V/f, FCC control permissible
- Increased inverter load: approx. 10% to 15%
- Operation only permissible with 4 kHz pulse frequency
- The output frequency is limited to 150 Hz.

Line commutating choke

Line commutating chokes are used to smooth voltage peaks or to bridge commutating dips. In addition, line commutating chokes reduce the effects of harmonics on the inverter and the power supply. If the line impedance is < 1 %, a line commutating choke must be used in order to reduce the current peaks.

In line with EN 61 000-3-2 regulations "Limits for harmonic currents with device input current ≤ 16 A per phase", there are special aspects for drives with 250 W to 550 W and 230 V single-phase supplies which can be used in non-industrial applications (1st environment).

For devices with 250 W and 370 W, it is necessary either to fit the recommended input chokes or to apply to the power utility company for authorization to connect the devices to the public power supply. No limits are currently defined in the EN 61 000-3-2 standard for professionally used devices with a connected load > 1 kW which means that the inverters with an output power ≥ 0.75 kW comply with the EN 61 000-3-2 standard.

Output choke

Output chokes can be supplied for reducing the capacitive currents and dV/dt in the case of motor cables > 50 m (shielded) or > 100 m (unshielded).

For max. permissible cable lengths, see Technical Data.

Gland plate

The gland plate facilitates the shield connection of power and control cables and ensure optimum EMC performance.

MICROMASTER 420

Options Variant dependent options

Technical data

LC filter

Mains voltage	3 AC 380 V to 480 V		
Current (at 40 °C/50 °C)	for frame size A	4.5 A/ 4.1 A	
	for frame size B	11.2 A/10.2 A	
	for frame size C	32.6 A/29.7 A	
Limiting of motor overvoltage	≤ 1078 V		
dV/dt limiting	≤ 500 V/μs		
Pulse frequency	4 kHz		
Max. motor frequency	150 Hz		
Max. permissible motor cable lengths	Shielded	200 m	
	Unshielded	300 m	
Insulation strength	Overvoltage category III to VDE 0110		
Electromagnetic compatibility	Up to 200 m motor cable length with emissions to Class A according to EN 55 011 in conjunction with filtered inverters and unshielded cables		
Conformity	CE according to the low-voltage directive 73/23/EEC		
Approvals	UL available soon		
Strain resistance	EN 60 068-2-31		
Humidity	95 % humidity, non-condensing		
Degree of protection	IP20 (to EN 60529)		
Insulation class	H (180 °C)		
Permissible temperature	Operation	-10 °C to +40 °C (+14 °F to +104 °F) to +50 °C (to +122 °F)	100 % P_n 80 % P_n
	Storage	-25 °C to +70 °C (-13 °F to +158 °F)	
Operational altitude	up to 2000 m	100 % P_n	
	2000 to 4000 m	62.5 % P_n	
Mounting position	Vertical		
Free space	Top	100 mm	
	Bottom	100 mm	
	Side	100 mm	
Connection system	Input, litz wire or terminal	1U1, 1V1, 1W1	
	Output, terminals	1U2, 1V2, 1W2	
Torque for power conductor connections	1.5 Nm to 1.8 Nm		
Weight, approx.	for frame size A	7 kg	
	for frame size B	11 kg	
	for frame size C	29 kg	

Max. permissible cable lengths from the motor to the inverter when using output chokes

The following table shows the maximum permissible cable lengths from the motor to the inverter when using output chokes.

Frame size (FS)	Output choke Type	Max. permissible motor cable lengths (shielded/unshielded) for a mains voltage of		
		200 V to 240 V ± 10 %	380 V to 400 V ± 10 %	401 V to 480 V ± 10 %
A	6SE6400-3TC00-4AD3	200 m/300 m	–	–
A	6SE6400-3TC00-4AD2	200 m/300 m	150 m/225 m	100 m/150 m
B	6SE6400-3TC01-0BD3	200 m/300 m	150 m/225 m	100 m/150 m
C	6SE6400-3TC03-2CD3	200 m/300 m	200 m/300 m	100 m/150 m

Selection and ordering data

The options listed here (filters, chokes, gland plates, fuses, and circuit-breakers) must be selected to match the inverter.

The inverter and the associated options have the same voltage ratings.

All options are certified to , except fuses. The fuses of Type 3NA3 are recommended for Europe.

Use in America requires @-listed fuses such as the Class NON range from Bussmann.

Mains voltage	Output		Inverter without filter	Order No. of the options		
	kW	hp		EMC filter Class A	EMC filter Class B	Additional EMC filter, Class B
1 AC 200 V to 240 V	0.12	0.16	6SE6420-2UC11-2AA1	–	–	–
	0.25	0.33	6SE6420-2UC12-5AA1	–	–	–
	0.37	0.50	6SE6420-2UC13-7AA1	–	–	–
	0.55	0.75	6SE6420-2UC15-5AA1	–	–	–
	0.75	1.0	6SE6420-2UC17-5AA1	–	–	–
	1.1	1.5	6SE6420-2UC21-1BA1	–	–	–
	1.5	2.0	6SE6420-2UC21-5BA1	–	–	–
	2.2	3.0	6SE6420-2UC22-2BA1	–	–	–
	3.0	4.0	6SE6420-2UC23-0CA1	–	–	–
3 AC 200 V to 240 V	0.12	0.16	6SE6420-2UC11-2AA1	6SE6400-2FA00-6AD0	6SE6400-2FB00-6AD0	–
	0.25	0.33	6SE6420-2UC12-5AA1	–	–	–
	0.37	0.50	6SE6420-2UC13-7AA1	–	–	–
	0.55	0.75	6SE6420-2UC15-5AA1	–	–	–
	0.75	1.0	6SE6420-2UC17-5AA1	–	–	–
	1.1	1.5	6SE6420-2UC21-1BA1	6SE6400-2FA01-4BC0	6SE6400-2FB01-4BC0	–
	1.5	2.0	6SE6420-2UC21-5BA1	–	–	–
	2.2	3.0	6SE6420-2UC22-2BA1	–	–	–
	3.0	4.0	6SE6420-2UC23-0CA1	–	–	–
	4.0	5.0	6SE6420-2UC24-0CA1	–	–	–
	5.5	7.5	6SE6420-2UC25-5CA1	–	–	–
	3 AC 380 V to 480 V	0.37	0.50	6SE6420-2UD13-7AA1	6SE6400-2FA00-6AD0	6SE6400-2FB00-6AD0
0.55		0.75	6SE6420-2UD15-5AA1	–	–	–
0.75		1.0	6SE6420-2UD17-5AA1	–	–	–
1.1		1.5	6SE6420-2UD21-1AA1	–	–	–
1.5		2.0	6SE6420-2UD21-5AA1	–	–	–
2.2		3.0	6SE6420-2UD22-2BA1	–	–	–
3.0		4.0	6SE6420-2UD23-0BA1	–	–	–
4.0		5.0	6SE6420-2UD24-0BA1	–	–	–
5.5		7.5	6SE6420-2UD25-5CA1	–	–	–
7.5		10.0	6SE6420-2UD27-5CA1	–	–	–
11		15.0	6SE6420-2UD31-1CA1	–	–	–
			Inverter with internal filter Class A			
1 AC 200 V to 240 V	0.12	0.16	6SE6420-2AB11-2AA1	–	–	6SE6400-2FS01-0AB0
	0.25	0.33	6SE6420-2AB12-5AA1	–	–	–
	0.37	0.50	6SE6420-2AB13-7AA1	–	–	–
	0.55	0.75	6SE6420-2AB15-5AA1	–	–	–
	0.75	1.0	6SE6420-2AB17-5AA1	–	–	–
	1.1	1.5	6SE6420-2AB21-1BA1	–	–	6SE6400-2FS02-6BB0
	1.5	2.0	6SE6420-2AB21-5BA1	–	–	–
	2.2	3.0	6SE6420-2AB22-2BA1	–	–	–
	3.0	4.0	6SE6420-2AB23-0CA1	–	–	6SE6400-2FS03-5CB0
3 AC 200 V to 240 V	3.0	4.0	6SE6420-2AC23-0CA1	–	–	6SE6400-2FS03-8CD0
	4.0	5.0	6SE6420-2AC24-0CA1	–	–	–
	5.5	7.5	6SE6420-2AC25-5CA1	–	–	–
3 AC 380 V to 480 V	2.2	3.0	6SE6420-2AD22-2BA1	–	–	6SE6400-2FS01-6BD0
	3.0	4.0	6SE6420-2AD23-0BA1	–	–	–
	4.0	5.0	6SE6420-2AD24-0BA1	–	–	–
	5.5	7.5	6SE6420-2AD25-5CA1	–	–	6SE6400-2FS03-8CD0
	7.5	10.0	6SE6420-2AD27-5CA1	–	–	–
	11	15.0	6SE6420-2AD31-1CA1	–	–	–

MICROMASTER 420

Options Variant dependent options

Selection and ordering data (continued)

Mains voltage	Output		Inverter without filter	Order No. of the options		
	kW	hp		Filter Class B with low leakage currents	LC filter	Line commutating choke
1 AC 200 V to 240 V	0.12	0.16	6SE6420-2UC11-2AA1	6SE6400-2FL01-0AB0	–	6SE6400-3CC00-4AB3
	0.25	0.33	6SE6420-2UC12-5AA1	–	–	–
	0.37	0.50	6SE6420-2UC13-7AA1	–	–	6SE6400-3CC01-0AB3
	0.55	0.75	6SE6420-2UC15-5AA1	–	–	–
	0.75	1.0	6SE6420-2UC17-5AA1	–	–	–
	1.1	1.5	6SE6420-2UC21-1BA1	6SE6400-2FL02-6BB0	–	6SE6400-3CC02-6BB3
	1.5	2.0	6SE6420-2UC21-5BA1	–	–	–
	2.2	3.0	6SE6420-2UC22-2BA1	–	–	–
	3.0	4.0	6SE6420-2UC23-0CA1	–	–	6SE6400-3CC03-5CB3
3 AC 200 V to 240 V	0.12	0.16	6SE6420-2UC11-2AA1	–	–	6SE6400-3CC00-3AC3
	0.25	0.33	6SE6420-2UC12-5AA1	–	–	–
	0.37	0.50	6SE6420-2UC13-7AA1	–	–	6SE6400-3CC00-5AC3
	0.55	0.75	6SE6420-2UC15-5AA1	–	–	–
	0.75	1.0	6SE6420-2UC17-5AA1	–	–	–
	1.1	1.5	6SE6420-2UC21-1BA1	–	–	6SE6400-3CC00-8BC3
	1.5	2.0	6SE6420-2UC21-5BA1	–	–	6SE6400-3CC01-4BD3
	2.2	3.0	6SE6420-2UC22-2BA1	–	–	–
	3.0	4.0	6SE6420-2UC23-0CA1	–	–	6SE6400-3CC01-7CC3
	4.0	5.0	6SE6420-2UC24-0CA1	–	–	6SE6400-3CC03-5CD3
3 AC 380 V to 480 V	0.37	0.50	6SE6420-2UD13-7AA1	–	6SE6400-3TD00-4AD0	6SE6400-3CC00-2AD3
	0.55	0.75	6SE6420-2UD15-5AA1	–	–	–
	0.75	1.0	6SE6420-2UD17-5AA1	–	–	6SE6400-3CC00-4AD3
	1.1	1.5	6SE6420-2UD21-1AA1	–	–	–
	1.5	2.0	6SE6420-2UD21-5AA1	–	–	6SE6400-3CC00-6AD3
	2.2	3.0	6SE6420-2UD22-2BA1	–	6SE6400-3TD01-0BD0	6SE6400-3CC01-0BD3
	3.0	4.0	6SE6420-2UD23-0BA1	–	–	–
	4.0	5.0	6SE6420-2UD24-0BA1	–	–	6SE6400-3CC01-4BD3
	5.5	7.5	6SE6420-2UD25-5CA1	–	6SE6400-3TD03-2CD0	6SE6400-3CC02-2CD3
	7.5	10.0	6SE6420-2UD27-5CA1	–	–	–
1 AC 200 V to 240 V	11	15.0	6SE6420-2UD31-1CA1	–	–	6SE6400-3CC03-5CD3
	Inverter with internal filter Class A					
	0.12	0.16	6SE6420-2AB11-2AA1	–	–	6SE6400-3CC00-4AB3
	0.25	0.33	6SE6420-2AB12-5AA1	–	–	–
	0.37	0.50	6SE6420-2AB13-7AA1	–	–	6SE6400-3CC01-0AB3
	0.55	0.75	6SE6420-2AB15-5AA1	–	–	–
	0.75	1.0	6SE6420-2AB17-5AA1	–	–	–
	1.1	1.5	6SE6420-2AB21-1BA1	–	–	6SE6400-3CC02-6BB3
	1.5	2.0	6SE6420-2AB21-5BA1	–	–	–
	2.2	3.0	6SE6420-2AB22-2BA1	–	–	–
3 AC 200 V to 240 V	3.0	4.0	6SE6420-2AB23-0CA1	–	–	6SE6400-3CC03-5CB3
	3.0	4.0	6SE6420-2AC23-0CA1	–	–	6SE6400-3CC01-7CC3
	4.0	5.0	6SE6420-2AC24-0CA1	–	–	6SE6400-3CC03-5CD3
3 AC 380 V to 480 V	5.5	7.5	6SE6420-2AC25-5CA1	–	–	–
	2.2	3.0	6SE6420-2AD22-2BA1	–	6SE6400-3TD01-0BD0	6SE6400-3CC01-0BD3
	3.0	4.0	6SE6420-2AD23-0BA1	–	–	–
	4.0	5.0	6SE6420-2AD24-0BA1	–	–	6SE6400-3CC01-4BD3
	5.5	7.5	6SE6420-2AD25-5CA1	–	6SE6400-3TD03-2CD0	6SE6400-3CC02-2CD3
	7.5	10.0	6SE6420-2AD27-5CA1	–	–	–
3 AC 380 V to 480 V	11	15.0	6SE6420-2AD31-1CA1	–	–	6SE6400-3CC03-5CD3

Selection and ordering data (continued)

Mains voltage	Output		Inverter without filter	Output choke	Gland plate	Order No. of the options			
	kW	hp				Fuse (see Catalog LV 10)	Circuit-breaker		
1 AC 200 V to 240 V	0.12	0.16	6SE6420-2UC11-2AA1	6SE6400-3TC00-4AD3	6SE6400-0GP00-0AA0	3NA3803	3RV1021-1DA10		
	0.25	0.33	6SE6420-2UC12-5AA1				3RV1021-1GA10		
	0.37	0.50	6SE6420-2UC13-7AA1				3RV1021-1HA10		
	0.55	0.75	6SE6420-2UC15-5AA1				3RV1021-1JA10		
	0.75	1.0	6SE6420-2UC17-5AA1				3NA3805 3RV1021-4AA10		
	1.1	1.5	6SE6420-2UC21-1BA1			6SE6400-3TC01-0BD3	6SE6400-0GP00-0BA0	3NA3807 3RV1021-4BA10	
	1.5	2.0	6SE6420-2UC21-5BA1					3RV1021-4DA10	
	2.2	3.0	6SE6420-2UC22-2BA1					3NA3812 3RV1021-4FA10	
	3.0	4.0	6SE6420-2UC23-0CA1			6SE6400-3TC03-2CD3	6SE6400-0GP00-0CA0	3NA3817	3RV1031-4HA10
3 AC 200 V to 240 V	0.12	0.16	6SE6420-2UC11-2AA1	6SE6400-3TC00-4AD3	6SE6400-0GP00-0AA0	3NA3803	3RV1021-1AA10		
	0.25	0.33	6SE6420-2UC12-5AA1				3RV1021-1DA10		
	0.37	0.50	6SE6420-2UC13-7AA1				3RV1021-1EA10		
	0.55	0.75	6SE6420-2UC15-5AA1				3RV1021-1GA10		
	0.75	1.0	6SE6420-2UC17-5AA1				3RV1021-1HA10		
	1.1	1.5	6SE6420-2UC21-1BA1			6SE6400-3TC01-0BD3	6SE6400-0GP00-0BA0	3NA3805 3RV1021-1KA10	
	1.5	2.0	6SE6420-2UC21-5BA1					3RV1021-4AA10	
	2.2	3.0	6SE6420-2UC22-2BA1					3NA3807 3RV1021-4BA10	
	3.0	4.0	6SE6420-2UC23-0CA1			6SE6400-3TC03-2CD3	6SE6400-0GP00-0CA0	3NA3810	3RV1021-4CA10
4.0	5.0	6SE6420-2UC24-0CA1			3NA3812	3RV1031-4EA10			
5.5	7.5	6SE6420-2UC25-5CA1			3NA3814	3RV1031-4FA10			
3 AC 380 V to 480 V	0.37	0.50	6SE6420-2UD13-7AA1	6SE6400-3TC00-4AD2	6SE6400-0GP00-0AA0	3NA3803	3RV1021-1CA10		
	0.55	0.75	6SE6420-2UD15-5AA1				3RV1021-1DA10		
	0.75	1.0	6SE6420-2UD17-5AA1				3RV1021-1EA10		
	1.1	1.5	6SE6420-2UD21-1AA1				3RV1021-1GA10		
	1.5	2.0	6SE6420-2UD21-5AA1				3RV1021-1HA10		
	2.2	3.0	6SE6420-2UD22-2BA1			6SE6400-3TC01-0BD3	6SE6400-0GP00-0BA0	3NA3805 3RV1021-1JA10	
	3.0	4.0	6SE6420-2UD23-0BA1					3RV1021-1KA10	
	4.0	5.0	6SE6420-2UD24-0BA1					3NA3807 3RV1021-4AA10	
	5.5	7.5	6SE6420-2UD25-5CA1			6SE6400-3TC03-2CD3	6SE6400-0GP00-0CA0		3RV1021-4CA10
7.5	10.0	6SE6420-2UD27-5CA1			3NA3810	3RV1031-4EA10			
11	15.0	6SE6420-2UD31-1CA1			3NA3814	3RV1031-4GA10			
			Inverter with internal filter Class A						
1 AC 200 V to 240 V	0.12	0.16	6SE6420-2AB11-2AA1	6SE6400-3TC00-4AD3	6SE6400-0GP00-0AA0	3NA3803	3RV1021-1DA10		
	0.25	0.33	6SE6420-2AB12-5AA1				3RV1021-1GA10		
	0.37	0.50	6SE6420-2AB13-7AA1				3RV1021-1HA10		
	0.55	0.75	6SE6420-2AB15-5AA1				3RV1021-1JA10		
	0.75	1.0	6SE6420-2AB17-5AA1				3NA3805 3RV1021-4AA10		
	1.1	1.5	6SE6420-2AB21-1BA1			6SE6400-3TC01-0BD3	6SE6400-0GP00-0BA0	3NA3807 3RV1021-4BA10	
	1.5	2.0	6SE6420-2AB21-5BA1					3RV1021-4DA10	
	2.2	3.0	6SE6420-2AB22-2BA1					3NA3812 3RV1021-4FA10	
	3.0	4.0	6SE6420-2AB23-0CA1			6SE6400-3TC03-2CD3	6SE6400-0GP00-0CA0	3NA3817	3RV1031-4HA10
3 AC 200 V to 240 V	3.0	4.0	6SE6420-2AC23-0CA1	6SE6400-3TC03-2CD3	6SE6400-0GP00-0CA0	3NA3810	3RV1021-4CA10		
	4.0	5.0	6SE6420-2AC24-0CA1			3NA3812	3RV1031-4EA10		
	5.5	7.5	6SE6420-2AC25-5CA1			3NA3814	3RV1031-4FA10		
3 AC 380 V to 480 V	2.2	3.0	6SE6420-2AD22-2BA1	6SE6400-3TC01-0BD3	6SE6400-0GP00-0BA0	3NA3805	3RV1021-1JA10		
	3.0	4.0	6SE6420-2AD23-0BA1				3RV1021-1KA10		
	4.0	5.0	6SE6420-2AD24-0BA1				3NA3807 3RV1021-4AA10		
	5.5	7.5	6SE6420-2AD25-5CA1			6SE6400-3TC03-2CD3	6SE6400-0GP00-0CA0		3RV1021-4CA10
	7.5	10.0	6SE6420-2AD27-5CA1					3NA3810	3RV1031-4EA10
	11	15.0	6SE6420-2AD31-1CA1					3NA3814	3RV1031-4GA10

MICROMASTER 420

Options

Variant independent options

Overview

Basic Operator Panel (BOP)

With the BOP, individual parameter settings can be made. Values and units are shown on a 5-digit display.



Basic Operator Panel (BOP)

A BOP can be used for several inverters. It can be directly mounted on the inverter or in a control cabinet door using a mounting kit.

Advanced Operator Panel (AOP)

The AOP enables parameter kits to be read out of the inverter or to be written into the inverter (upload/download). Different parameter kits can be stored in the AOP. It has a plain text display with the possibility of switching between several languages.



Advanced Operator Panel (AOP)

Up to 30 inverters can be controlled from an AOP via USS. It can be directly mounted on the inverter or in a control cabinet door using a mounting kit.

Asian Advanced Operator Panel (AAOP)

The AAOP is the Chinese version of the AOP operator panel. It has an enhanced display and supports the operating languages of Chinese (simplified) and English.



Asian Advanced Operator Panel (AAOP)

PROFIBUS module

For a complete PROFIBUS connection with up to ≤ 12 Mbaud. Remote control of the inverter is possible with the PROFIBUS module. Remote control and operation at the inverter can be combined using an operator panel plugged onto the PROFIBUS module. The PROFIBUS module can be supplied by an external 24 V DC power supply and is thus also active when the inverter is disconnected from the power supply.

Connection by means of a 9-pin Sub-D connector (available as an option).

DeviceNet module

For networking the inverters to the DeviceNet fieldbus system widely used on the American market. A maximum transmission rate of 500 Kbaud is possible. Remote control of the inverter is possible with the DeviceNet module. Remote control and operation at the inverter can be combined using an operator panel plugged onto the DeviceNet module.

The connection to the DeviceNet bus system is made using a 5-pin connector with terminal strip.

CANopen module

Using the CANopen communications module, an inverter can be linked to the CANopen fieldbus system and remote control is then possible.

Remote control and operation at the inverter can be combined using an operator panel plugged onto the CANopen module.

The module is connected to the bus system through a 9-pin Sub-D connector.

Connection kit for PC to inverter

For controlling an inverter directly from a PC if the appropriate software has been installed (e.g. STARTER). Isolated RS-232 adapter module for reliable point-to-point connection to a PC. Includes a Sub-D connector and an RS-232 standard cable (3 m).

Connection kit for PC to AOP

For connecting a PC to an AOP or AAOP. Offline programming of inverters and archiving of parameter kits possible. Includes a desktop attachment kit for an AOP or AAOP, an RS-232 standard cable (3 m) with Sub-D connectors and a universal power supply unit.

Operator panel door mounting kit for single inverter

For mounting an operator panel in a control cabinet door. Degree of protection IP56. Contains a cable adapter module with screwless terminals for use with user's own RS-232-cables¹⁾.

AOP door mounting kit for multiple inverters (USS)

For mounting an AOP or AAOP in a control cabinet door. Degree of protection IP56. The AOP or AAOP can communicate with several inverters by means of the RS-485 USS protocol. The 4-pin connecting cable from the AOP or AAOP to the RS-485 terminals of the inverter and to the 24 V user terminal strip is not included²⁾.

Start-up tools

- **STARTER** is a graphic start-up software for guided start-up for MICROMASTER 410/420/430/440 frequency inverters under Windows NT/2000/XP Professional. Parameter lists can be read out, altered, stored, entered and printed.
- **DriveMonitor** is a start-up software for list-oriented programming of frequency inverters. This program executes under Windows 95/98/NT/2000/XP Professional.

Both programs are included on the Docu CD which is provided with every inverter.

1) A shielded cable of type Belden 8132 (28 AWG) is recommended. The maximum cable length is 5 m for RS-232.

2) A shielded cable of type Belden 8/32 (28 AWG) is recommended. The maximum cable length is 10 m for RS-485.

Selection and ordering data

The options listed here are suitable for all MICROMASTER 420 inverters.

Options	Order No.
Basic Operator Panel (BOP)	6SE6400-0BP00-0AA0
Advanced Operator Panel (AOP)	6SE6400-0AP00-0AA1
Asian Advanced Operator Panel (AAOP)	6SE6400-0AP00-0AB0
PROFIBUS module	6SE6400-1PB00-0AA0
DeviceNet module	6SE6400-1DN00-0AA0
CANopen module	6SE6400-1CB00-0AA0
RS485/PROFIBUS bus connector	6GK1500-0FC00
Connection kit for PC to inverter	6SE6400-1PC00-0AA0
Connection kit for PC to AOP	6SE6400-0PA00-0AA0
Operator panel door mounting kit for single inverter	6SE6400-0PM00-0AA0
AOP door mounting kit for multiple inverters (USS)	6SE6400-0MD00-0AA0

Technical data of the communication modules

		PROFIBUS module 6SE6400-1PB00-0AA0	DeviceNet module 6SE6400-1DN00-0AA0
			
Size (height x width x depth)	161 mm x 73 mm x 46 mm		
Degree of protection	IP20		
Degree of pollution	2 to IEC 60 664-1 (DIN VDE 0110/T1), no condensation permitted during operation		
Strain resistance	to DIN IEC 60 068-2-6 (if module is installed correctly)		
• Stationary	Deflection	0.15 mm in the frequency range of 10 Hz to 58 Hz	
	Acceleration	19.6 m/s ² in the frequency range of 58 Hz to 500 Hz	
• Transport	Deflection	3.5 mm in the frequency range of 5 Hz to 9 Hz	
	Acceleration	9.8 m/s ² in the frequency range of 9 Hz to 500 Hz	
Climatic category (during operation)	3K3 to DIN IEC 60 721-3-3		
Cooling method	Natural air cooling		
Permissible ambient or cooling agent temperature			
• Operation	-10 °C to +50 °C (+14 °F to +122 °F)		
• Storage and transport	-25 °C to +70 °C (-13 °F to +158 °F)		
Relative humidity (permissible humidity rating)			
• Operation	≤ 85 % (non-condensing)		
• Storage and transport	≤ 95 %		
Electromagnetic compatibility	Emission Interference	to EN 55 011 (1991) Class A to IEC 60 801-3 and EN 61 000-4-3	
Power supply	6.5 V ± 5 %, max. 300 mA, internal from inverter or 24 V ± 10 %, max. 350 mA, external		6.5 V ± 5 %, max. 300 mA internal from inverter or 24 V, max. 60 mA from DeviceNet-Bus
Output voltage	5 V ± 10 %, max. 100 mA, galvanically isolated supply • for terminating the serial interface bus or • for supplying the OLP (Optical Link Plug)		-
Data transmission rate	max. 12 Mbaud		125, 250 and 500 Kbaud

MICROMASTER 420

Options

Variant independent options

Technical data of the communication modules (continued)

CANopen module
6SE6400-1CB00-0AA0



Size (height x width x depth)	161 mm x 73 mm x 46 mm
Degree of protection	IP20
Degree of pollution	2 to IEC 60 664-1 (DIN VDE 0110/T1), no condensation permitted during operation
Strain resistance	to IEC 60 068-2-6 (if module is installed correctly)
• Stationary	Deflection Acceleration 0.15 mm in the frequency range of 10 Hz to 58 Hz 19.6 m/s ² in the frequency range of 58 Hz to 500 Hz
• Transport	Deflection Acceleration 3.5 mm in the frequency range of 5 Hz to 9 Hz 9.8 m/s ² in the frequency range of 9 Hz to 500 Hz
Climatic category (during operation)	3K3 to DIN IEC 60 721-3-3
Cooling method	Natural air cooling
Permissible ambient or cooling agent temperature	
• Operation	-10 °C to +50 °C (+14 °F to +122 °F)
• Storage	-40 °C to +70 °C (-40 °F to +158 °F)
• Transport	-25 °C to +70 °C (-13 °F to +158 °F)
Relative humidity (permissible humidity rating)	
• Operation	≤ 85 % (non-condensing)
• Storage and transport	≤ 95 %
Power supply	The CAN bus is supplied from the inverter power supply
Data transmission rate	10, 20, 50, 125, 250, 500, 800 Kbaud and 1 Mbaud

Documentation

Selection and ordering data

Type of documentation	Language	Order No.
Docu pack , supplied with each inverter, containing CD-ROM ¹⁾ and Getting Started Guide ²⁾ (paper version)	Multilanguage	6SE6400-5AB00-1AP0
Operating instructions²⁾ (paper version)	German	6SE6400-5AA00-0AP0
	English	6SE6400-5AA00-0BP0
	French	6SE6400-5AA00-0DP0
	Italian	6SE6400-5AA00-0CP0
	Spanish	6SE6400-5AA00-0EP0
Parameter list²⁾ (paper version)	German	6SE6400-5BA00-0AP0
	English	6SE6400-5BA00-0BP0
	French	6SE6400-5BA00-0DP0
	Italian	6SE6400-5BA00-0CP0
	Spanish	6SE6400-5BA00-0EP0

1) The CD-ROM contains operating instructions, parameter list, commissioning tools STARTER

and DriveMonitor, multilanguage

2) Available on Internet at <http://www.siemens.com/micromaster>

MICROMASTER 420 inverter

Frame size	1/3 AC 200 V to 240 V	3 AC 380 V to 480 V
A	0.12 kW to 0.75 kW	0.37 kW to 1.5 kW
B	1.1 kW to 2.2 kW	2.2 kW to 4 kW
C	3 kW to 5.5 kW	5.5 kW to 11 kW

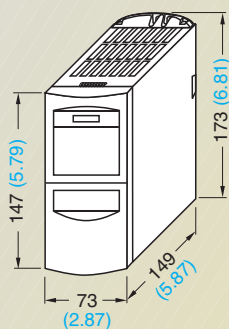

Inverter frame size **A**

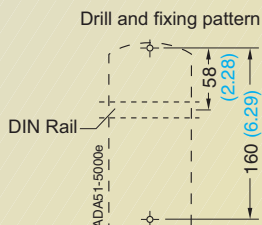

Fixing with
2 x M4 bolts, 2 x M4 nuts, 2 x M4 washers,
or snap onto the DIN rail
Tightening torque with washers fitted:
2.5 Nm
Ventilation clearance required at top and
bottom: 100 mm

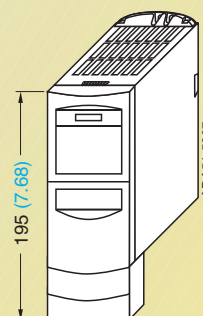

Inverter frame size **A**
with **gland plate**

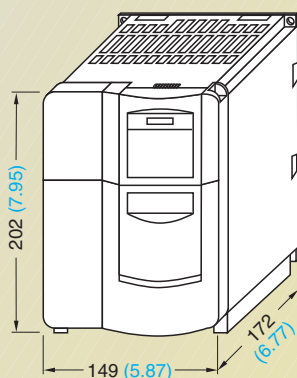

Inverter frame size **B**

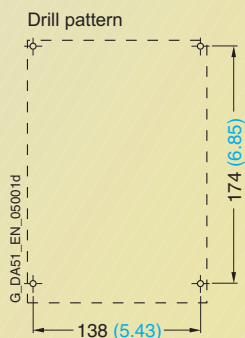

Fixing with
4 x M4 bolts, 4 x M4 nuts, 4 x M4 washers
Tightening torque with washers fitted:
2.5 Nm
Ventilation clearance required at top and
bottom: 100 mm

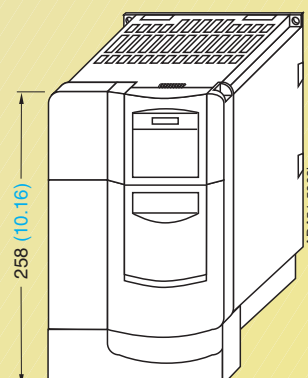

Inverter frame size **B**
with **gland plate**

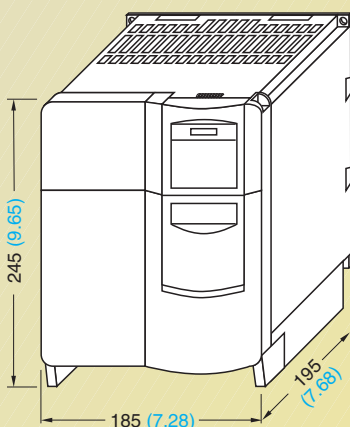

Inverter frame size **C**

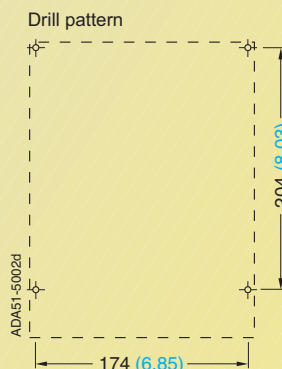

Fixing with
4 x M5 bolts, 4 x M5 nuts, 4 x M5 washers
Tightening torque with washers fitted:
3.0 Nm
Ventilation clearance required at top
and bottom: 100 mm

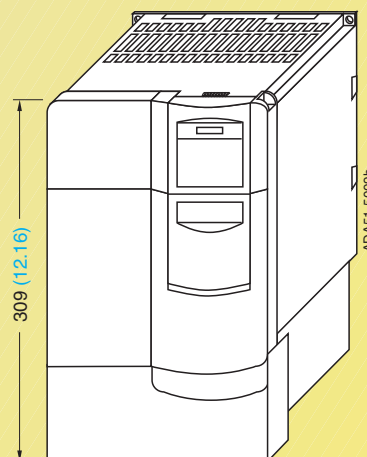

Inverter frame size **C**
with **gland plate**

With the communications module, the mounting depth
increases by 23 mm (0.91 inches).

All dimensions in mm (values in brackets are in inches)

MICROMASTER 420

Dimension drawings

Filters and chokes

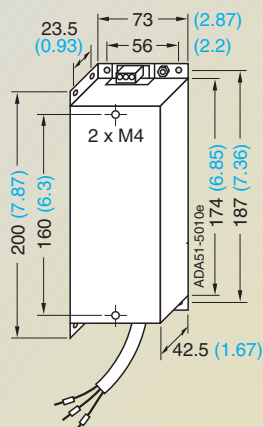

Filter frame size **A**

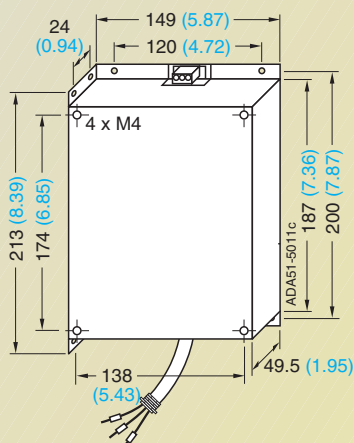

For frame size **B**

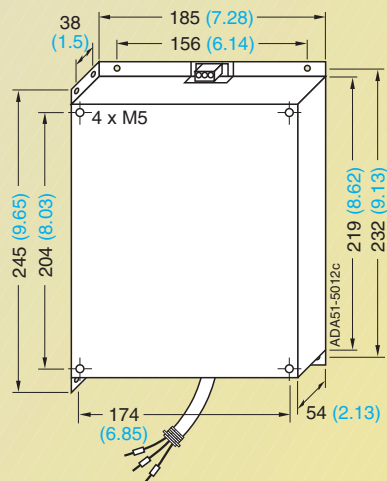

For frame size **C**

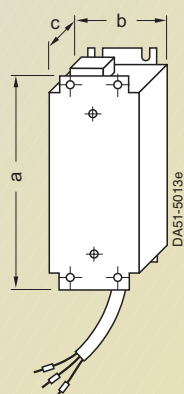

Line commutating choke for frame size **A**

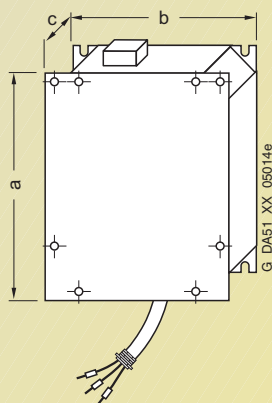

For frame sizes **B** and **C**

Line commutating choke for	Dimensions			Weight (max.) kg
	a	b	c	
Frame size A	200 (7.87)	75.5 (2.97)	50 (1.97)	0.8
Frame size B	213 (8.39)	150 (5.91)	50 (1.97)	1.3
Frame size C	245 (9.65)	185 (7.28)	50 (1.97)	2.3

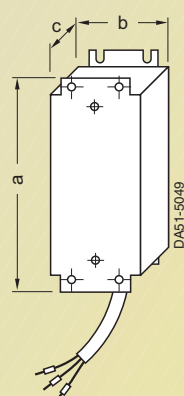

Output choke for frame size **A**
6SE6400-3TC00-4AD2
6SE6400-3TC00-4AD3

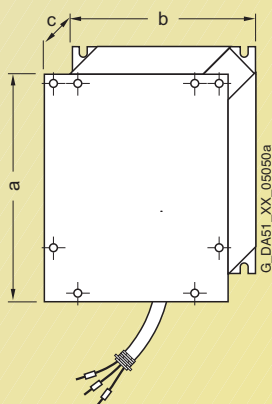

For frame sizes **B** and **C**
6SE6400-3TC01-0BD3
6SE6400-3TC03-2CD3

Output choke type 6SE6400-	Dimensions			Weight (max.) kg
	a	b	c	
3TC00-4AD2	200 (7.87)	75.5 (2.97)	110 (4.33)	1.95
3TC00-4AD3	200 (7.87)	75.5 (2.97)	50 (1.97)	0.8
3TC01-0BD3	213 (8.39)	150 (5.91)	70 (2.76)	3.4
3TC03-2CD3	245 (9.65)	185 (7.28)	80 (3.15)	5.6

All dimensions in mm (values in brackets are in inches)

LC filter

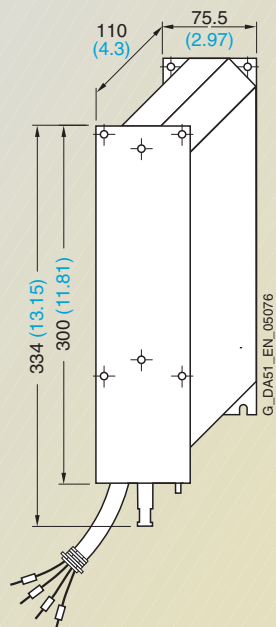

Fixing with M4 bolts

LC filter for frame size A

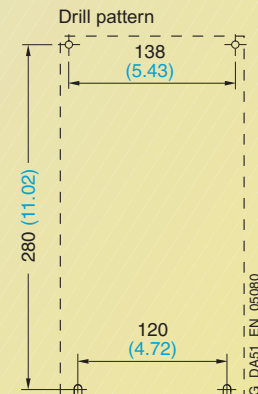
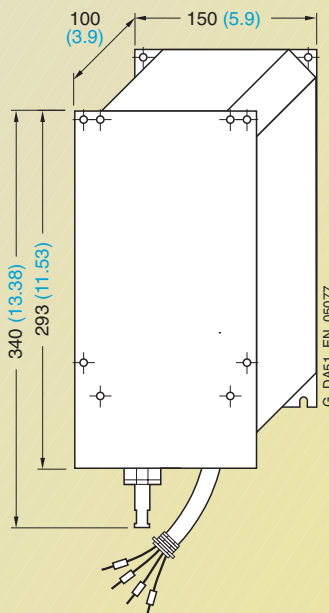

Fixing with M4 bolts

LC filter for frame size B

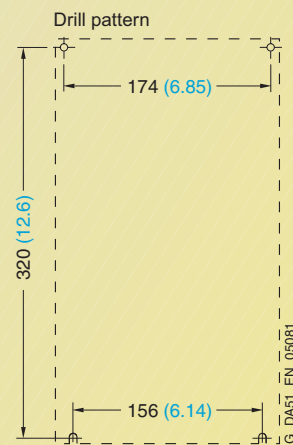
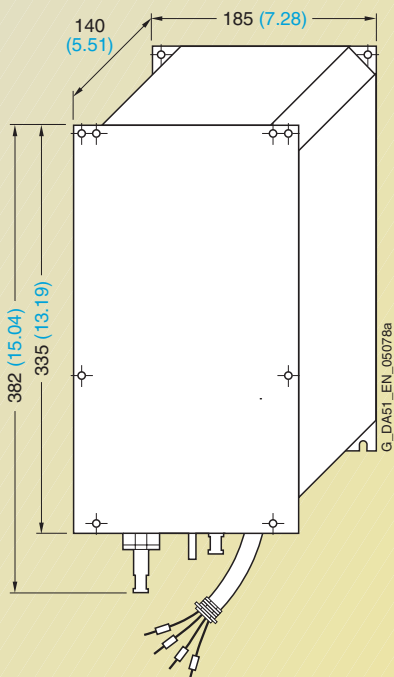

Fixing with M5 bolts

LC filter for frame size C

All dimensions in mm (values in brackets are in inches)

MICROMASTER 420

Dimension drawings

Assembly of inverter and options

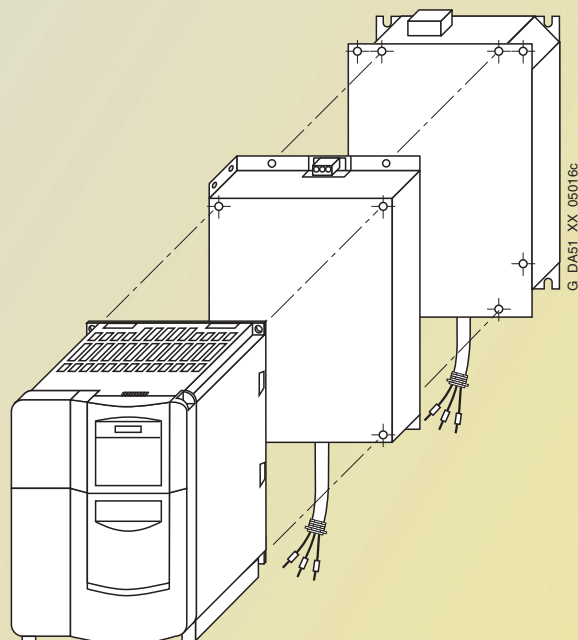

Example:
Assembly of
inverter, filter and choke
If additional options are
required, they must be mounted
at the side.

2